

YCP Series



Convert chips into high value
轉換廢屑為高附加價值



Compressed Block 屑餅

CHIP COMPACTOR

廢屑壓縮機

 **TungYu**

What the benefit is after using Tung Yu Chip Compactor?

在使用廢屑壓縮機之後，你將能獲得哪些效益？

- Depends on different materials, the volume of chips can be reduced to 1/5~1/50.
- Only less than 5% remaining cutting fluids in the compressed block, and more than 95% cutting fluids can be recycled.
- Reduction of transportation and labor costs.

- 依照不同材料，廢屑體積可減小1/5 ~ 1/50。
- 廢屑壓縮塊含油率僅5%以下，切削液可回收率高達95%以上。
- 降低搬運人工、車資等費用成本。

Remarks

The following material is not applicable: HRC 25+; elastic & long chips; easy spontaneous combustion material (such as Magnesium); material that might possibly damage the inner surface of extrusion area (such as "screws, bolts, tool knife and other); raw sewage of Medical trash.

備註

以下的金屬屑不可擠壓：硬度超過HRC25以上的鐵屑、極具彈性的長捲屑、易自燃的材料(如鎂等)對擠壓機的螺桿集內缸體有損傷的物質(如螺栓螺釘、車床刀具、邊角料及易燃物等)未處理的醫療廢棄物等。

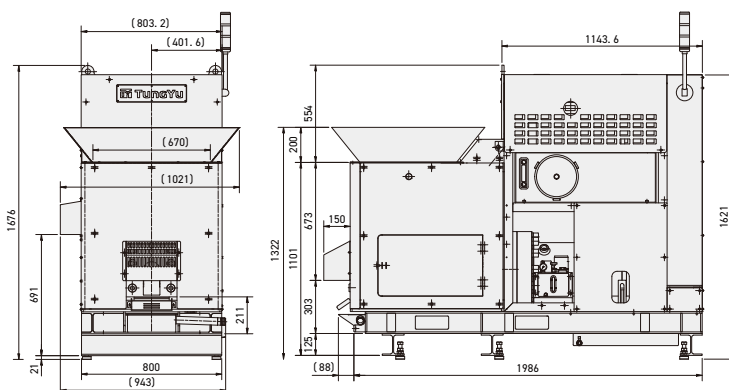

Specification 機台規格表

ITEM 項目			YCP-100H	YCP-103H
Max. Compression Force	壓縮能力	tons		100
Max. Working Pressure	最大使用壓力	kg/cm ²		210
Chip Cross-section Dia.	產出之壓縮塊斷面	mm		φ 90
Compression Surface Pressure	壓縮面壓	kg/cm ²		1570
Oil Tank Volume	油箱容積	L	120	300
Motor of Compression Cylinder	壓縮缸馬達	kW	5.5	14.9
Vertical Axial Motor	縱軸馬達	kW		0.75
Horizontal Axial Motor	橫軸馬達	kW		0.4
Hopper Volume	入料盒容量	L		100
Height of Hopper	入料盒高度	mm		1301
Machine Size	外觀尺寸	mm	L2160 x W1021 x H1655	L2531 x W1121 x H1992
Cycle Time	一次循環時間	sec.	40	20
(By Material)	(依材料別)			
Compressing Capacity	每小時壓縮量	kg/hr	60-90	120-180
(By Material)	(依材料別)			
Machine Weight (With Hydraulic Oil)	機械重量(含液壓油)	kg	1800	2520

Crusher Machine (optional) 粉碎機(選配)

- Depends on the length of chips, some particular may need to be crushed before compress process.
- Continual feeding for Chip Compactor to reduce cycle time and increase performance.

- 根據捲屑的長短，有些捲屑建議選擇粉碎機進行粉碎後方可擠壓。
- 可連續供料至廢屑壓縮機，降低入料時間並提升效益。



ITEM 項目		TC-150
Machine size	外觀尺寸	L1440 x W1350 x H1458mm
Motor	馬達功率	7.5kW
RPM	馬達轉速	1750rpm
Reduction ratio	減速機	1:50
Torque	扭矩	1819N.m
Machine Weight	機械重量	1190 kg (Approx.) 1190 公斤(大約)
Crush Capacity	每小時粉碎量	360 kg/hr (by material) 360 公斤/小時 (依材料別)

本機適合
擠壓材質

Suitable for
Compression



銅
Copper



鋁
Aluminum

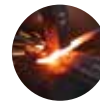

鑄鐵
Casting Iron



不鏽鋼
Stainless Steel

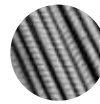

一般鋼材 SS、SC
General steel material,
such as SS、SC

Infeed/Outfeed Conveyors (optional) 出／入料輸送帶(選配)

- Tailor-made for working with crusher and chip compactor, enhancing chips processing and recycling efficiency.
- Available in various dimensions to suit different production line, with customization options upon request.
- 專為搭配粉碎機與廢屑壓縮機設計，強化廢屑處理與回收效率。
- 多款尺寸規格，適用不同產線配置，亦可依需求客製化調整。

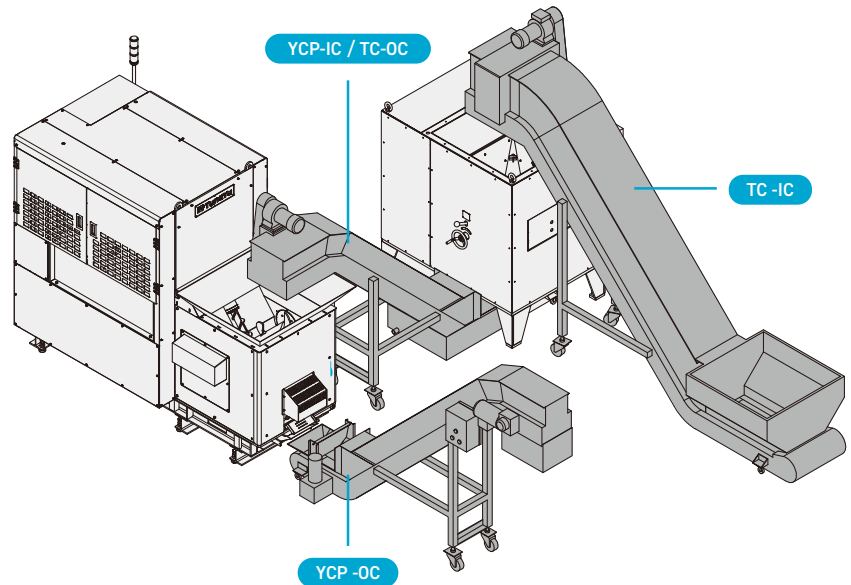

ITEM 項目			TC-OC	TC-IC	YCP-IC	YCP-OC
Equipment Compatibility	配合設備		Crusher 粉碎機	Crusher 粉碎機	Chip compactor 廢屑壓縮機	Chip compactor 廢屑壓縮機
Dimensions	外觀尺寸	mm	3219 x 480 x 1916	3426 x 800 x 2420	3219 x 800 x 1916	2615 x 304 x 1850
Infeed Hopper Size	入料盒尺寸	mm	480 x 1170	800 x 837	800 x 1170	355 x 445
Conveyor Belt Width	輸送帶寬度	mm	411	610	411	304
Discharge Height from Floor	出料口與地面間距	mm	1370	1665	1370	1280
Conveyor Motor Power	輸送帶馬力	kW			0.4	

Cutting Fluids Purification Equipment (optional) 切削液淨化再生處理設備(選配)

- Combining filtration, oil-water separation, and ozone sterilization to purify water and extend tool life.
- Consumable-free design for low maintenance cost and improve environment.
- 整合雜質過濾，油水分離與臭氧殺菌，有效淨化水質，延長刀具壽命。
- 免耗材設計降低維護成本，助力環境改善與製程升級。



ITEM 項目		BEST-1
Machine size	外觀尺寸	L520 x W410 x H880mm
Net Weight	淨重	45kg
Capacity	內桶容量	35L
Power Supply	電源功率	Single Phase.220V AC 50Hz 0.042Kw
Power Consumption	消耗功率	Consumption of 1 KWH of electricity in 24 hours
Pump Caliber	處理流量	10-30 Lit / Minute
Ozone Value	臭氧值	500mg /hr (produce 500 mg of ozone per hour)



台灣總公司 Headquarters

東毓油壓機械股份有限公司
Tung Yu Hydraulic Machinery Co., Ltd.

540 南投市永興路12號 (南崗工業區)
No. 12, Yongxing Rd., Nangang Industrial Park,
Nantou City, Nantou County 540, Taiwan
T + 886 49 2253588 F + 886 49 2252998 E tungyu@tungyu.com

中國寧波公司 China Ningbo

東毓(寧波)油壓工業有限公司
Tung Yu (Ningbo) Hydraulic Industries Co., Ltd.

315221 中國浙江省寧波市鎮海區蛟川街道東信路666號
No. 666, Dongxin Road, Jiaochuan Street, Zhenhai District,
Ningbo City, Zhejiang Province, China.
T + 0574-55333028 F + 0574-86598057 E ningbo@tungyu.com
全國免費服務專線 Free Hot Line 40011-33028