



Heavy Duty
Custom-made
Forming Machine
大型客製成型機系列



We are proud to say Tung Yu is
your first choice of
hydraulic forming machinery.

東毓深耕成型技術 持續擴展應用領域



Tung Yu - Tailor-Made Solutions Provider

Tung Yu, with ISO 9001 approved and CE certified, is highly experienced in the field of hydraulic machinery since 1983. Tung Yu manufactures a wide assortment of products, from 5 tons hydraulic press to 13,000 tons conveyor belt production line and we offer a comprehensive One-Stop Shopping service for customers. Our product line includes: Compression Molding Machines, Rubber and (Liquid) Silicon Injection Molding Machines, Conveyor Belt Vulcanizing Machines, Tire Molding Machines, Retreading and Solid Tire Molding Machines.

東毓油壓機械股份有限公司，自1983創立以來，秉持著董事長楊楨彬先生之「穩健踏實、永續經營」經營理念，以「誠信」立足市場。「Tung Yu」品牌行銷全球六十餘國。承製能力範圍廣闊，鎖模力由5噸小型油壓沖床至13,000噸的輸送帶硫化機，均能承製。主要機械產品線：熱壓成型機、橡矽(液態)膠射出成型機、輸送帶硫化機、輪胎硫化機、翻新胎硫化機以及各式油壓機械，產品應用領域跨足各大產業。未來發展以創新為目標，深耕「力量與熱量載具」之核心技術，成為成型技術的領先者，為客戶創造最大價值。



總公司 Headquarters



南投市南崗工業區 Nantou City



中國寧波 Ningbo China

日本東京 日東株式會社
Japan - Tokyo Branch NITTO Co., Ltd.
印度孟買 孟買辦事處
India - India Branch, Tung Yu
(India) Liaison Office

■ Heavey Duty Custom-made Forming Machine
大型機客製成型機系列

03 Steel Cord Conveyor Belt Vulcanizing Machine / Line
鋼索輸送帶硫化機生產線

07 Conveyor Belt Vulcanizing Machine / Line
輸送帶硫化機

09 ROTOCURE
鼓式硫化機

13 Post Type
大型熱壓成型機-柱型

19 Other Types
大型熱壓成型機-其他

22 Global Sales Network
全球銷售網路

Steel Cord Conveyor Belt Vulcanizing Machine / Line

鋼索輸送帶硫化機生產線

Tung Yu is the manufacturer of steel cord conveyor belt vulcanizing machines. The capacity is ranging up to 13,000 ton as to customer's requirements in the market. Comply with multi-station operation, we establish the convenient and safety process in production. With different products and needs from customers, Tung Yu provides the custom-made service. Curing press could be with main cylinders on top or bottom design to fit factory layout, on both sides equipped with automation guiding mechanism to make sure material belt at centering position. Tung Yu has stronger experience on the mechanical design, program edition, machine installation and turn-key facility arrangement along with safety operation and efficiency productivity. Total solution provider as Tung Yu is always to create the best value for our customers with successfully.

東毓製作之鋼索輸送帶硫化機，噸數可依客戶需求規劃設計，承製實績可達13,000噸以上；搭配多站式作業，在操作上建立方便且安全的作業程序；針對不同產品與客戶需求，東毓提供客製化服務，主機油缸可為上置式或下置式設計，二側有自動靠模裝置，可以確保物料在中間不偏移。

東毓公司從機構設計、程式編輯、機台安裝及整廠設備規劃等，都有成熟的經驗，並兼具安全工作環境與產能考量，東毓提供一系列全方位解決方案，可為客戶創造更大的價值。

Dimensions 構造

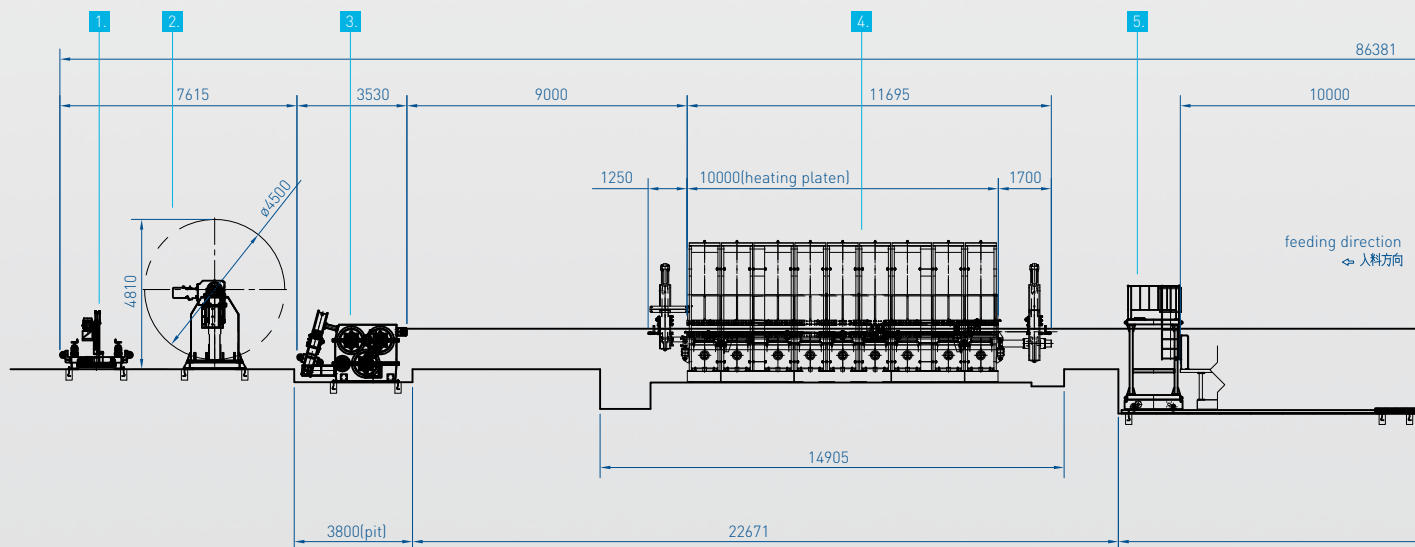

1 Cutting Unit / 2 Wind Up Station / 3 Pull Roll Stand / 4 Curing Press / 5 Inspection Platform / 6 Compactor Lorry / 7 Comb / 8 Splicing Machine / 9 Hydraulic Clamper & Tensioner / 10 Bobbin Device

※ Custom designed available 可依需求做客製化設計

※ Unit單位 : mm

Features 特寫說明

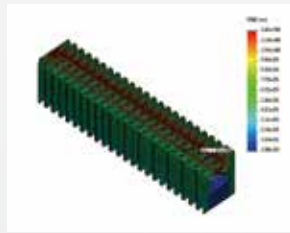
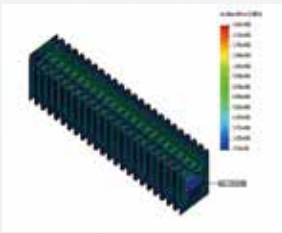

- Utilizing CAE (Computer Aided Engineering) for stress and deformation with Finite Element Analysis to make sure the structure of main frame with sufficient safety factor.
- 設計同時採用CAE應力及FEA形變有限元素分析，確保主機強度達安全係數標準。

- Comb : ensure the pitch of steel cord precisely.
- 固定梳子架：與液壓夾持及伸張機配合，確保準確的產品間隙。

- Hydraulic clamper and tensioner : align the steel cords to the parallel side and keep the position. Apply necessary tension onto steel cord for production.
- 液壓夾持及伸張機：彙整各方向鋼索成一平面，並維持鋼索張力。

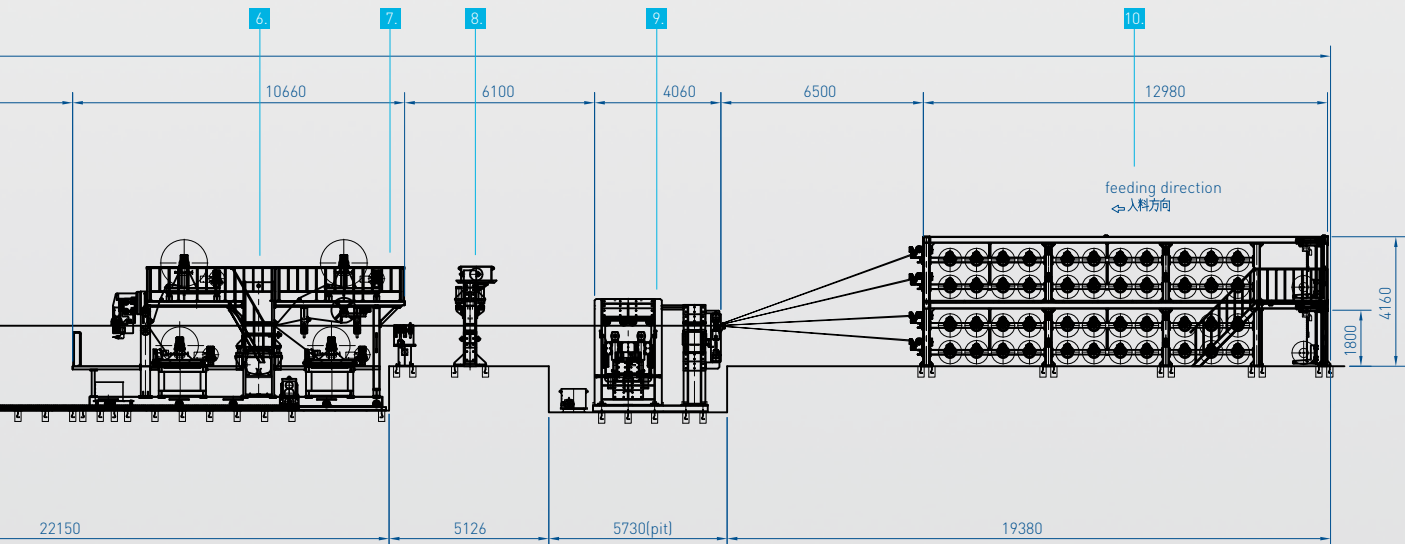

- 1 剪刀組 / 2 收料組 / 3 捲取機 / 4 硫化機 / 5 檢查台 / 6 壓台台車 / 7 固定梳子架 / 8 接頭機 / 9 液壓夾持及伸張機 / 10 錠子架

TCP-13104-S-PCD-UP

Steel Cord Conveyor Belt Vulcanizing Machine (Down Stroke)

鋼索輸送帶硫化機(上置式)

Mechanical feature at a glance

- Central control system by PLC and touch screen.
- Equipped with cooling system on the bottom of cylinders to prevent oil temperature increase and maintain performance.
- The bottom of cylinders is contacted to platen with full pressing area to have even pressure and better product quality.
- The seal of cylinders is located far from platen to have longer life cycle.
- Top cap of cylinders is designed with oil return hole to prevent product polluted from leaking.
- Heating platen size customized design is available.
- 全機採用PLC附加觸控螢幕系統連線控制。
- 油缸體底部有冷卻系統，可避免油溫上升，油品耐久性佳。
- 油缸底部接觸盤面，加壓面積較大，面壓較均勻，客戶產品品質較易管控。
- 主缸密封元件，離熱盤較遠，使用環境溫度較低；密封元件使用壽命較長。
- 油缸頂蓋有液壓油洩漏回收孔，防止液壓油汙染產品。
- 熱盤尺寸可依客戶需求設計。

Dimensions 構造

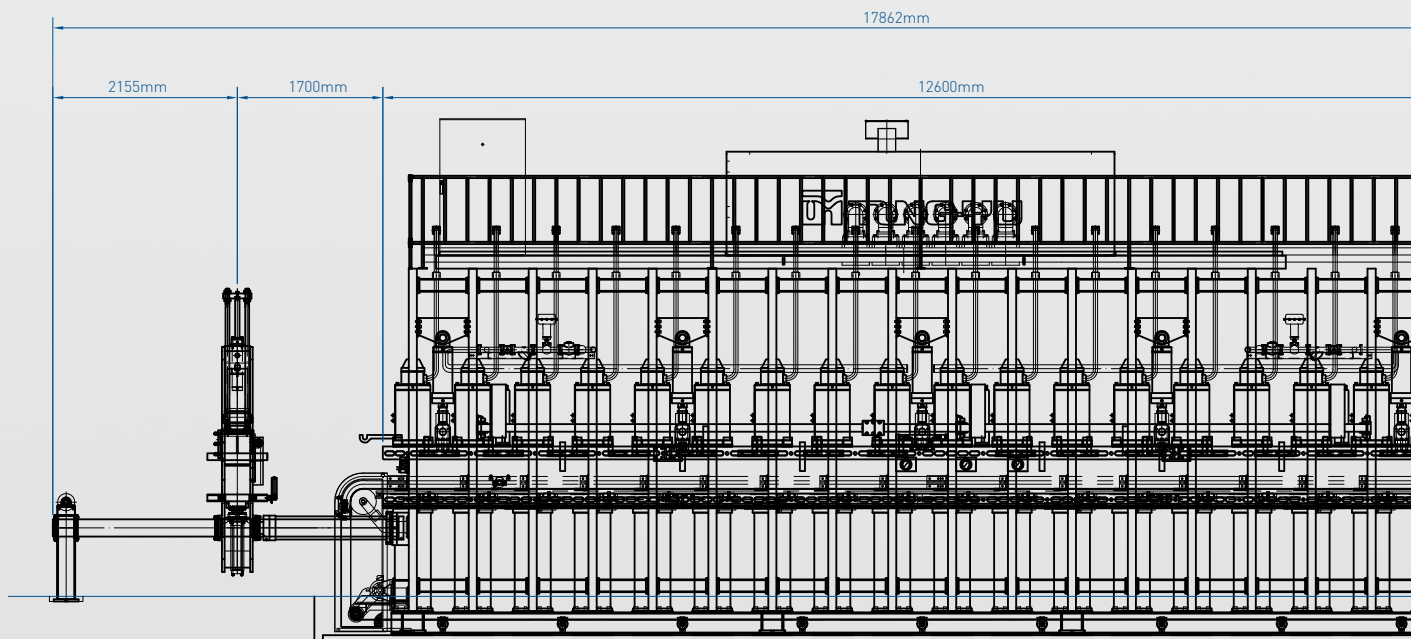

Steel Cord Conveyor Belt
Vulcanizing Machine / Line
鋼索輸送帶硫化機生產線

Conveyor Belt Vulcanizing
Machine / Line
輸送帶硫化機

ROTOCURE
鼓式硫化機

Post Type
大型熱壓成型機
柱型

Other Types
大型熱壓成型機
其他

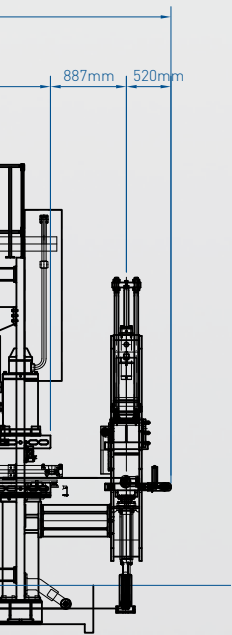
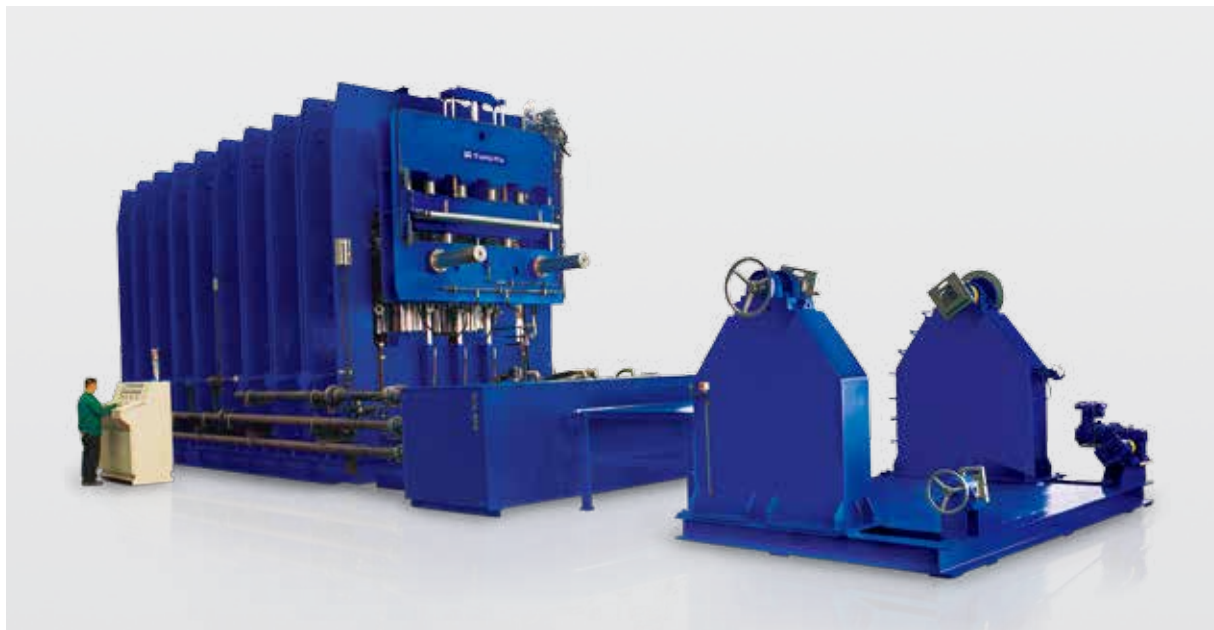

Features 特寫說明

- Multi-ram distribution on the platen without moveable traverse to reduce the material cost.
- The bottom of cylinders is contacted to platen with more pressing area to have better surface pressure.
- 小油缸多點分部，直接施壓於熱盤上面，無中座之設計，大大降低材料成本。
- 油缸底部接觸盤面，加壓面積較大，面壓較優化。

TCP-8600-PCD-UP

Bridge Type Conveyor Belt Vulcanizing Machine (Down Stroke)

龍門型平板硫化機 (上置式)

Mechanical feature at a glance

- Equipped with auto spacer bar adjusting system to make sure the material in center line process.
- The inside and outside cylinders line could be controlled independently as to different pressure setup from products.
- Designed with synchronized gear rack mechanism controlled by linear transducer to make sure all movement in parallel.
- 二側有自動靠模裝置，可以確保物料在中間位置不偏移。
- 內側油缸和外側油缸可依產品生產壓力分別設定及控制。
- 齒輪連結裝置，搭配以位置尺定位的子缸，增進整個盤面移動時的平衡性。

Products 製成品

- Flat conveyor belt
- 平板輸送帶

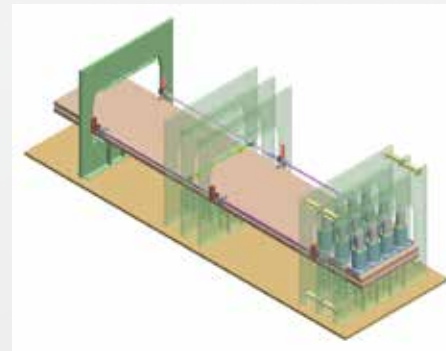

3D Simulation of Hydraulic System
油路3D示意圖

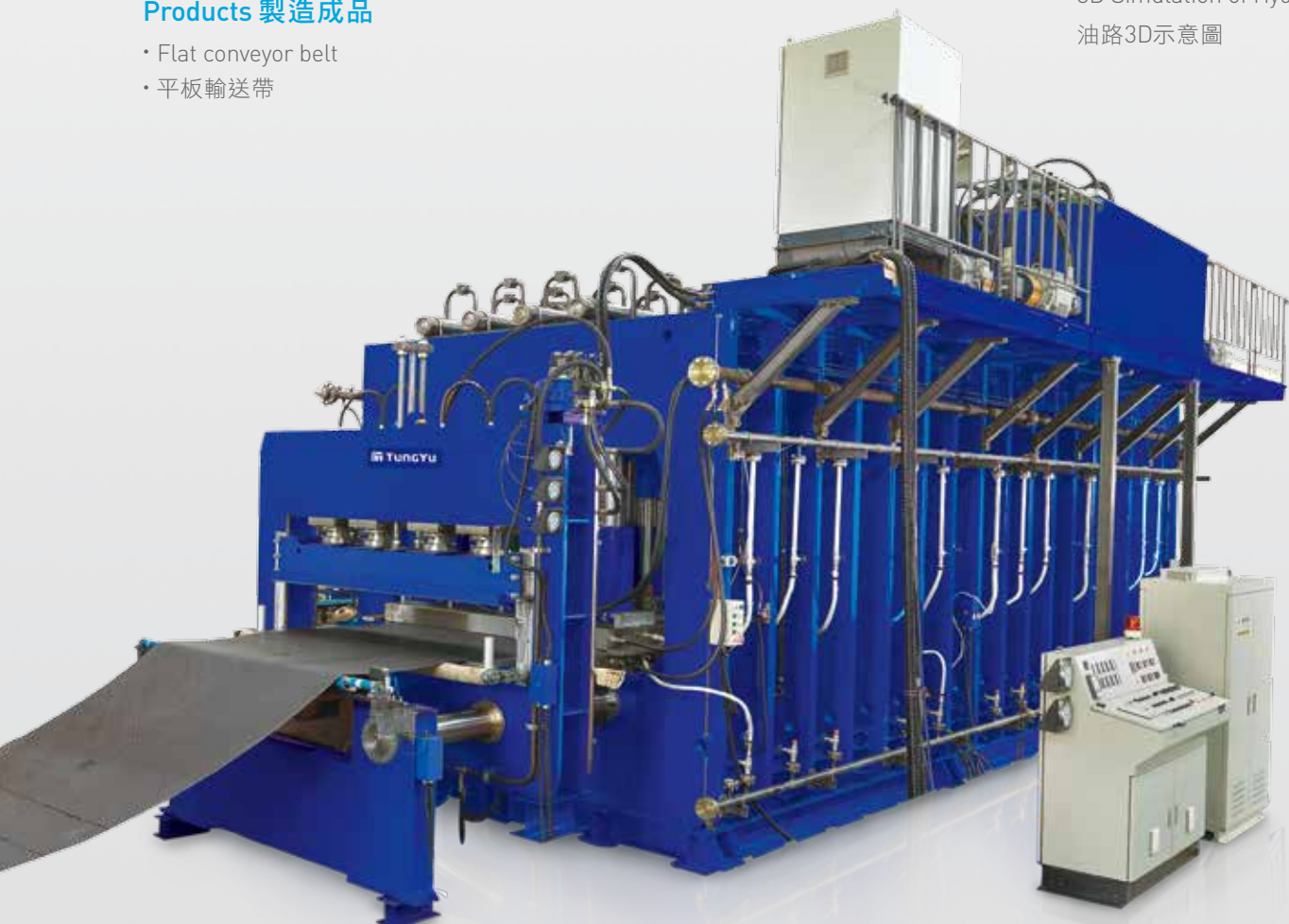

TPS-450-PCD-UP Track Vulcanizing Machine 履帶硫化機

Mechanical feature at a glance

- Suitable for making track for agriculture reapers, industrial machines and automation remoting vehicles.
- Optional equipment with mold removal and product lift to improve production process and save labor cost.
- 製作農業用收割機履帶，工業機械、自動遙控車輛傳動履帶。
- 搭配履帶生產流程，具有自動移模及離型後產品吊掛機構，可減少人力投入，達到生產流程最佳化。



TPS-26-S-PCD C Type Splicing Machine 鵝式接頭機

Mechanical feature at a glance

- Joint conveyor belt ends. Front section designed with movable tie bar to ensure structure durability.
- 專用於輸送帶末端硫化連接，機台前附有插銷特殊設計，確保機構不變形。



ROTOCURE

鼓式硫化機

ROTOCURE machine can supply continued curing and compressing for special required product. Mechanism strength is based on CAE and FEA analysis to ensure enough safety factor. Utilizing Sweden-made SANDVIK steel belt for stable and even working pressure (option: Berndorf or other brands). Otherwise, steel belt position is adjusted by automatic photoelectric tracking device. Once belt position offset, alarm message will be active for safety purpose. Individually radiation auxiliary heating system is optional temperature control for curing process. Operation is quite accuracy and facility. Depends on each customized need, ROTO CURE also provides different let-off and wind-up station and other auxiliary equipment to guarantee product quality. For automatically process and higher production capacity, TungYu ROTO CURE will be most functional equipment.

ROTOCURE鼓式硫化機為可連續加壓及加熱之硫化設備，用於對產品表面形狀及質量有特殊要求之生產條件；機台選用瑞典原裝進口SANDVIK撓性鋼帶（BERNDORF或其他品牌搭配），確保工作壓力穩定均勻；設計同時採用CAE應力及形變有限元素分析，確保主機強度達安全係數標準；張力輪附自動光電感應式中央糾偏控制，及外側鋼帶超限停機安全裝置，確保機台操作安全；可搭配輔助加壓加熱系統，採用紅外線加熱管，溫度可分區控制。藉由客戶不同產品流程需求，可搭配不同的收放料及輔助機構設計，確保產品生產品質，主機硫化過程持續不間斷，東毓製造之鼓式硫化機是提升產能最佳自動化設備。

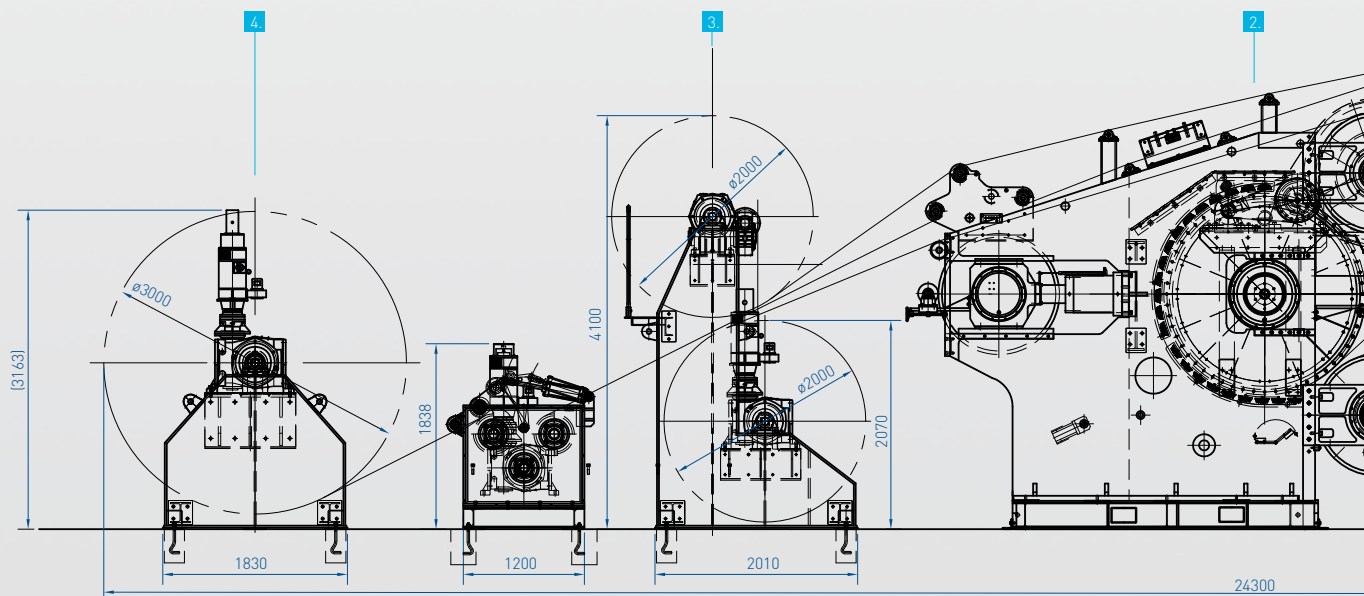

1 Raw Material Let-Off Mechanism / 2 Rotocure / 3 Line / Product / Pattern Wind-up Mechanism /
4 Product Wind-up Mechanism

※ Custom designed available 可依需求做客製化設計

※ Unit單位 : mm

Features 特寫說明



- Three customized let-off and wind-up devices for a large variety conveyor belt.
- 客製化三放三收前後段裝置，可生產多樣化不同產品。



- Particular design of steel belt and main drum exchanging. Simplify and shorten working hours in maintenance.
- 鋼帶與主滾輪快拆設計，維修簡易省時。



- Steel belt equipped with automatic photoelectric tracking device and deviation is detected and corrected automatically.
- 鋼帶附自動光電感應式中央糾偏控制，可自動偵測及修正超限位置。

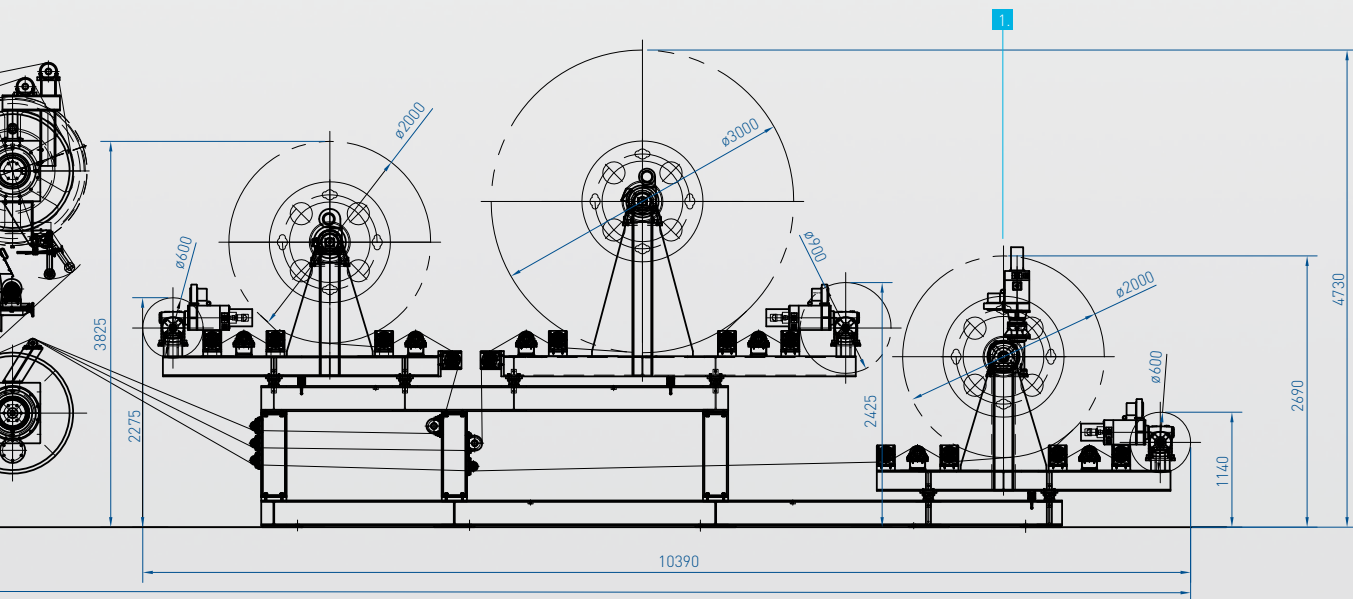

1 送料部組 / 2 主機部組 / 3 襯布 / 產品 / 模具布捲取機 / 4 收料部組

TRC- § 2000 X W2380

ROTOCURE

鼓式硫化機

Mechanical feature at a glance

- Continuous vulcanizing process provides high production efficiency and stable quality.
- Auto latching chuck for safety and promptly loading/unloading material shaft.
- Control system by PLC and HMI to easily and precisly set up temperature, pressure, speed and other production parameters .
- Auxiliary equipment such as let-off and wind-up device, steel belt quick exchanging mechanism and tension side spacer is available.
- Customized design for CE and OSHA conformity machine.
- 連續式加壓加熱，生產效率高且產品品質穩定。
- 自動卡準式夾頭，上下原料與產品迅速安全。
- 控制系統採PLC系統及HMI選配，溫度、壓力、速度及生產參數設定方便且準確。
- 可依客戶需求提供收放料裝置、鋼帶快拆、檔板拉撐等輔助設備。
- 可依客戶要求承製CE或OSHA機型。



TRC- ϕ 2000 X W2400 (CE)

ROTOCURE

鼓式硫化機

Mechanical feature at a glance

- Utilizing Sweden-made SANDVIK steel belt for stable and even working pressure (option: Berndorf or other brands).
- Auxiliary radiation heating system. Heating zones controlled individually.
- 使用瑞典SANDVIK鋼帶，確保工作壓力穩定均勻（BERNDORF或其它品牌選配）。
- 附輔助加熱系統，採用紅外線加熱管，溫度可分區控制。



Technical Specifications 機器規格表

Machine Type	機型			TRC- ϕ 1200	TRC- ϕ 1500	TRC- ϕ 1800	TRC- ϕ 2000
Heating Drum Diameter	主滾輪直徑		mm	ϕ 1200	ϕ 1500	ϕ 1800	ϕ 2000
Vulcanization Length	有效硫化長度		mm	2500	3500	4000	4500
Max. Product Width	產品最大寬度	(1)	mm	Custom made according to max. product width required. 依客戶之產品最大寬度設計			
Max. Product Thickness	產品厚度		mm	0.5 ~ 25			
Max. Heating Temperature	最大硫化溫度	(2)		160 ~ 220°			
Max. Surface Pressure	最大面壓		Kg / cm ²	5			
Roundness Of Heating Drum	主滾輪真圓度			0.08			
Steel Belt	使用鋼帶	(3)		SANDVIK 1650 SM			
Heating Method (Of Heating Drum)	主滾輪使用熱源	(4)		Steam or Thermic 蒸汽或熱煤油			
Auxiliary Heating	輔助加熱裝置	-		•	•	•	•
Auxiliary Pressure Drum (Optional)	輔助加壓輪（選配）	(5)		•	•	•	•
Clean Device For Heating Drum And Steel Belt	主滾輪及鋼帶清潔裝置			X	•	•	•
Pre-heating for Lower Reversing Drum (Optional)	下滾輪預熱（選配）			•	•	•	•
Steel Belt Tracking Device	鋼帶糾偏機構			•	•	•	•

Remarks

- Machine width can be designed according to max. product width requirements.
- Heating drum can be designed to pressure vessel type[optional].
- Woven belt is available[optional].
- Heating by Steam or Thermic is decided by customers.
- Max. line pressure of auxiliary pressure drum: 120kg/cm.

備註

- 機器寬度可依客戶產品最大寬度要求設計。
- 滾輪可選配壓力容器加熱。
- 可選配編織帶。
- 熱源由客戶通知蒸汽或熱煤油。
- 輔助加壓輪最大出力120kg/cm²。

TYC-28X4-A-S-PCD

Heavy Duty with Multi-ram Design - Post Type

多缸超大噸數 - 柱型

Mechanical feature at a glance

- For new structure design take CAE software to analyze the stress and deformation to make sure the frame strength with enough safety factor.
- Main frame designed with insulation cover to keep temperature stability and prevent heat loss.
- Movable traverse moving out with heating platen and lower mold to keep heating and prevent heavy mold from deformation.
- Control system by PLC and HMI to easily set up temperature, pressure, speed and auto process.
- Multi-deck, double shuttle and mold opening way is available for customized design.
- 針對新結構設計，採用CAE應力及形變有限元素分析，確保主機強度達安全係數標準。
- 主機部搭配隔熱罩，有效保持硫化時溫度，降低能源消耗成本。
- 下熱盤與模具隨中座滑出，在裝載超大型模具時機構強度無慮，並持續對模具進行保溫。
- 控制系統採PLC及HMI 觸控式螢幕，溫度、壓力、速度及自動化動作設定程序方便且準確。
- 特別機台層數、雙向進出模、脫模方式可依據客戶需求設計。



Steel Cord Conveyor Belt
Vulcanizing Machine / Line
鋼索輸送帶硫化機生產線

Conveyor Belt Vulcanizing
Machine / Line
輸送帶硫化機

ROTOCURE
鼓式硫化機

Post Type
大型熱壓成型機
柱型

Other Types
大型熱壓成型機
其他

Dimensions 構造

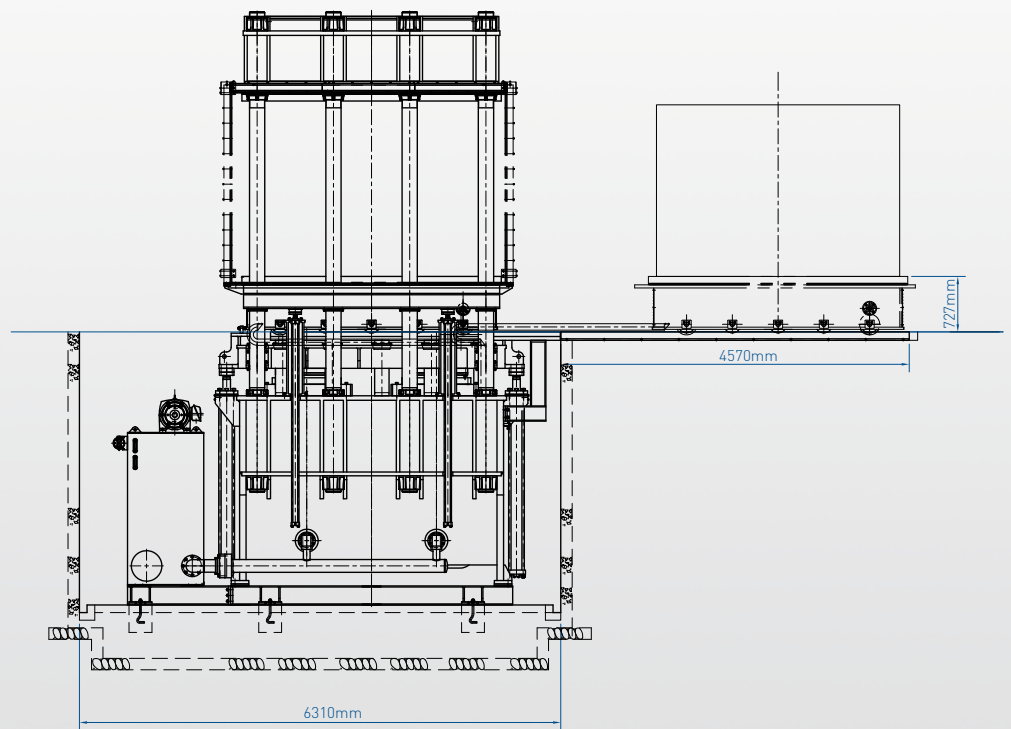

Features 特寫說明

- Main frame available: post type, down stroke, bridge type and slab side type to apply to different customer requirements. On mold fixation, loading direction, factory site layout...etc.
- 機構型式多樣選擇—柱型、油缸上置式、龍門型和旁板型能滿足不同模具固定需求、入料方向、廠房配置等特別需求。

TYC-V-20X4-A-S-PCD (CE)

Heavy Duty with Multi-ram Design - Post Type

多缸超大噸數 - 柱型

Products 製造成品

- Conveyor belt / Rubber and synthetic sheet / Mat / Block / Tile / Carpet / Car engine cover / Dock fender / Water pipe / Tank track
- 輸送帶 / 橡膠板合成板 / 橡膠地磚、複合材料地毯 / 汽車引擎蓋 / 港口碰墊 / 地下道水管 / 戰車履帶



Steel Cord Conveyor Belt
Vulcanizing Machine / Line
鋼索輸送帶硫化機生產線

Conveyor Belt Vulcanizing
Machine / Line
輸送帶硫化機

ROTOCURE
鼓式硫化機

Post Type
大型熱壓成型機
柱型

Other Types
大型熱壓成型機
其他

TYC-14X4-S-PCD



TYC-10X6-S-PCD-UP



TYC-32-A-S-PCD-UP

Heavy Duty Design - Post Type

超大噸數- 柱型

Mechanical feature at a glance

- With down stroke design to reduce the working height.
- Equipped with locking pin to prevent main ram free moving to make sure operator safety.
- Available to set up half or full stroke on shuttle system.
- Apply for fender and big size rubber parts test. Vertical compression and shear force test are available..
- 使用上置式油缸設計，降低工作高度。
- 主油缸配置防落插銷，確保操作員安全。
- 滑動板可設定50%或100%出模，以符合製程。
- 適用於碰墊及大型橡膠製品測試，垂直及剪力測試都可執行。



TYC-V-38-3RT-S-PCD

Heavy Duty Design - Post Type

超大噸數- 柱型

Mechanical feature at a glance

- Customized specification is available for molding various large dimension products.
- After mold opening, lower mold moves forward to operating area with 200% stroke and operator can easily load/unload.
- 客製化規格，適用於多種多樣化大型產品生產。
- 出模離型後，下模再往投料區移動，方便作業員取成品與放料。

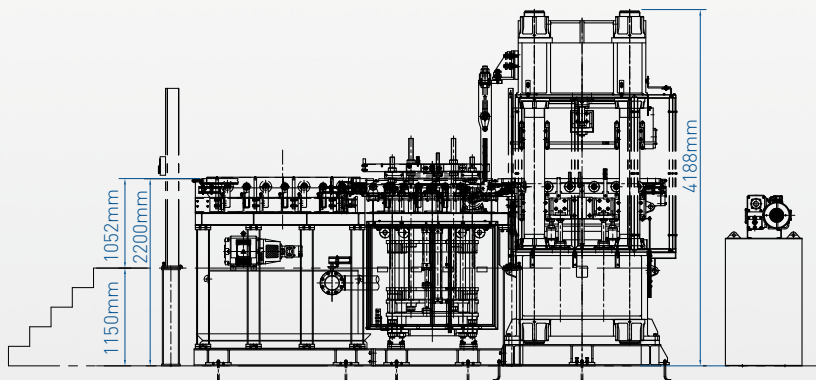

Features 特寫說明

- Customized specification is available for molding various large dimension products.
- 大型熱壓成型機及平板硫化為客製化機型，適用於多種多樣化大型產品生產。

THP-1200-A-PCD-2L(CE)

Heavy Duty With Multi-ram Design - Slab Side Type 多缸超大噸數 - 旁板型

Mechanical feature at a glance

- Slab side with multi-ram design for duty clamping force operation.
- Double molds operation at front side to save plant space and increase productivity.
- Low working height design for ergonomic engineering.
- Left /right side with operating panel for easily operation.
- This model is designed for gaskets manufacture and also for wide range products.
- 旁板式多缸設計，提供高噸數鎖模力操作。
- 前方雙換模機構，提升生產效率，並節省廠房空間。
- 低工作高度，符合人體工學。
- 左右側皆配置操作盒，增加操作便利性。
- 機台主要可供墊片量產用，以及其他廣泛領域之材質生產用。



Dimensions 構造

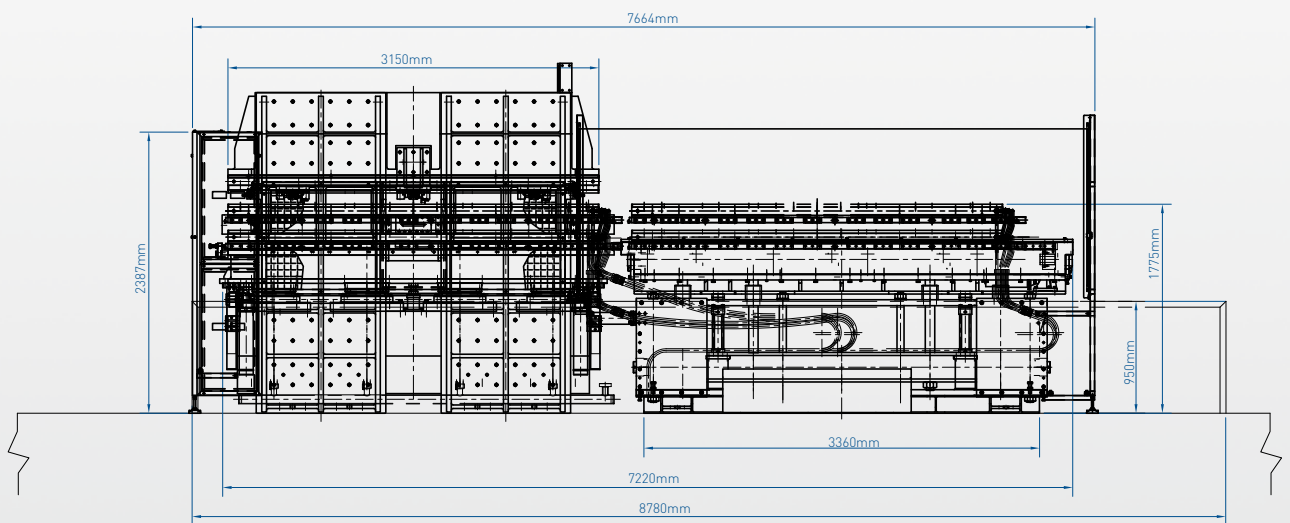

Products 製造成品

- Gaskets
- 墊片



Features 特寫說明

- Sliding plate driven by a ball screw to reduce friction and move smoothly.
- 滑動板由滾珠螺桿驅動，提高動作順暢度及降低摩擦力。

TPS-250-PCD-UP(CE)

C - Frame With Multi-ram Design

多缸C型機構

Mechanical feature at a glance

- Strong and firm steel structure design.
- Down stroke design with lower working height for ergonomic operating.
- Equipped with safety catcher (optional) to prevent down stroking structure from free movement.
- Movable caging design for safety operation and make sure the working area on C frame.
- 採用鋼板焊材確保結構設計。
- 上置式設計使操作高度降低，符合人體工學
- 安全夾頭（選配）提昇上置式機構的安全性。
- 移動式圍網設計，提供操作安全性及確保C型機構工作空間。





Japan - Tokyo Branch 日本分公司

株式会社 日東
NITTO Co., Ltd.
東京都台東区東上野1-20-6丸幸ビル602
602 Maruko Building, 1-20-6 Higashiueno,
Taito-Ku, Tokyo 110-0015 Japan
T + 81 3 5812 2812 F + 81 3 5812 2815
info@kk-nitto.co.jp
www.kk-nitto.co.jp/index.html

Turkey 土耳其 代理商

Vizyotek San.Mak.Paz.Bak. Ve Ser.Hiz.
San.Tic.Ltd. Sti.
21.yy Cd. 18.Sk. Zigana Sit. No.4 Bademli
Bursa Türkiye
T + 90 224 5491208 F + 90 224 5491209
vizyotek@vizyotek.com.tr

Russia 俄羅斯 代理商

Rti-Snab Ltd.
Polzunova st. 3, Tula 300028, Russia
T + 7 495 7617422 (Moscow) + 7 4872 656367 (Tula)
F + 7 495 3352867 (Moscow) + 7 4872 356367 (Tula)
rti-snab@yandex.ru

Tung Yu (India) Liaison Office 印度孟買 辦事處

Salnik Solutions&Tung Yu (India) Liaison Office
509-510 A'Wing, 4th Floor, Orchard Mall Rd.,
Royal Palms Estate, 169-Aarey Milk Colony Rd.,
Goregaon (East), Mumbai - 400 065, India
T + 91 22 2877 6547 F + 91 22 2877 3147
tungyul@tungyuindia.com

Korea 韓國 代理商

Jugi Corporation
Room No. 916, 129, Bongeunsa-ro (Nonhy-
un-dong Geopyeong Town), Gangnam-gu,
Seoul, 06121 Korea
T + 82 2 5478254 F + 82 2 5488254
info@jugicorp.com

Iran 伊朗代理商

Artin Tech Trading & Engineering Co.
Apt. 407, Vanak Trading Center
No. 8, Vanak Ave. Tehran, Iran
T + 98 21 88870 488 F + 98 21 88870 490
artintech@artin-tech.com
manager@artin-tech.com

Europe 歐洲 代理商

Rep International
15, rue du Dauphine 69964 Corbas, France
T + 33 4 72215353 F + 33 4 72512235
commercial@repinjection.com

Thailand 泰國 代理商

Centre West International (Thailand) Co., Ltd.
89/10 Moo 9, Bangkaew, Bangplee, Samut-
prakarn 10540, Thailand
T + 66 2753 7201 F + 66 2753 6925
Mobile + 60 1221 88972
derek@centrewest.com.my

South Vietnam 南越南 代理商

CÔNG TY TNHH CHIEH KE INT' L VN
杰格國際越南責任有限公司
Ap An My, Xa An Dien, Huyen Ben Cat, Tinh Binh
Duong, Vietnam
T + 84 650 3554128/29/30/31 F + 84 650 3554166
chiehkevn@gmail.com
sales@full-shine.com

North America 北美洲 代理商

Rep Corporation
310 Katom Dr, Kodak, TN 37764, United States
T + 1 847 697 7210 F + 1 847 697 6829
dwilliams@repcorp.com

Malaysia 馬來西亞 代理商

Centre West Industrial Supplies Sdn. Bhd.
No. 9, Jalan TSB 8, Taman Industri Sungai
Buloh, 47000 Petaling Jaya Selangor,
Malaysia
T + 60 3 6157 6688 F + 60 3 6157 0651
Mobile + 60 1221 88972
derek@centrewest.com.my

Affiliates 關係企業

G-WAY 吉瑞精機

G-WAY Machinery Industrial Co., Ltd
540 南投市永興路12號(南崗工業區)
No.12, Yongsing Rd., Nan Kung Industrial Zone, Nantou
City 540, Taiwan R.O.C.
T + 886 49 2258239 F + 886 49 2258229
gway1.taiwan@msa.hinet.net
www.g-way.com.tw

Indonesia 印尼 代理商

PT. Asia Talenta Mandiri
CBD@Jababeka Blok F-21, Jl. Niaga Raya Kav.
AA3, Jababeka, Cikarang, Bekasi, Jawa Barat 17530,
Indonesia.
T + 62(0)21 2908 2716 F + 62(0)21 2908 2803
yogisusonof@gmail.com

Philippines 菲律賓 代理商

Legaspi Import & Export Corporation
5/F Bloomingdale Building 205 Salcedo Street
Legaspi Village, Makati City 1229 Philippines
T + 63 2892 2681 F + 63 922 817 2689
solidstatemakati@gmail.com



台灣總公司 Headquarters

東毓油壓機械股份有限公司
Tung Yu Hydraulic Machinery Co., Ltd.
540 南投市永興路12號 (南崗工業區)
No.12, Yongsing Rd., Nan Kung Industrial Zone
Nantou City 540, Taiwan R.O.C.
T + 886 49 2253588 F + 886 49 2252998
tungyu@tungyu.com
www.tungyu.com

中國寧波公司 China Ningbo

東毓(寧波)油壓工業有限公司
Tung Yu (Ningbo) Hydraulic Industries Co., Ltd.
315200中國浙江省寧波市鎮海區
鎮海經濟開發區金城路158號
No.158, Jincheng Rd., Zhenhai Economic Development
Zone, Zhenhai District, Ningbo, Zhejiang, China
T + 0574-55333028 / 0574-86599066 F + 0574-86599050
ningbo@tungyu.com
全國免費服務專線 Free Hot Line
40011-33028

Representative