

| TYC Series

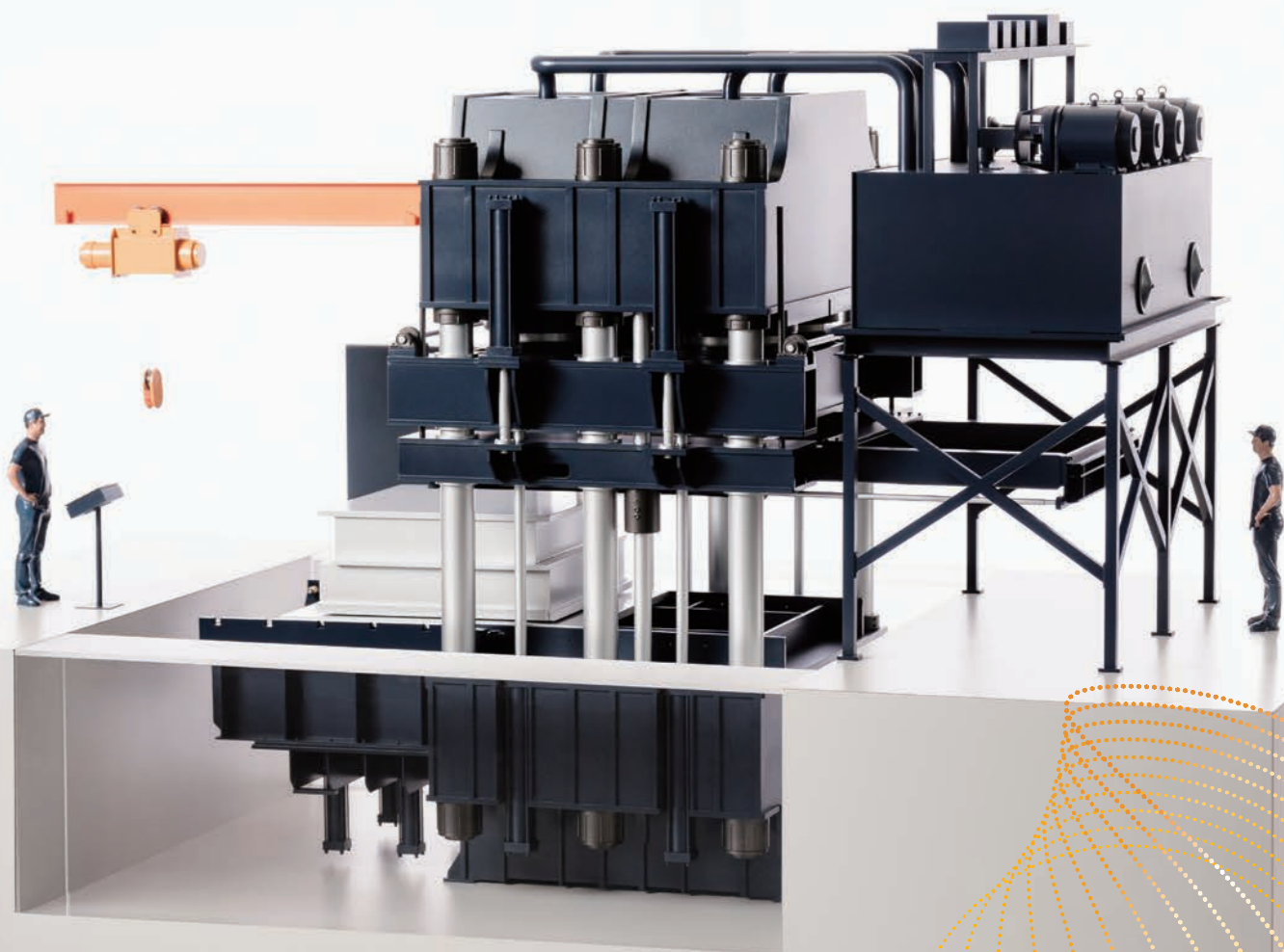

RUBBER COMPRESSION FORMING MACHINE

橡膠熱壓成型機系列

 **TungYu**

FORMING INNOVATION

東毓深耕成型技術 持續擴展應用領域

Tung Yu specializes in crafting cutting-edge hydraulic machines, from rubber compression to injection molding, revolutionizing industries across 75+ nations.

Join us in shaping the future of technology and experiencing the Tung Yu difference!

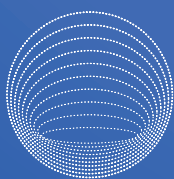

TYC

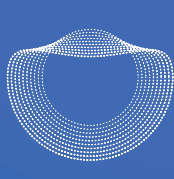

TIP

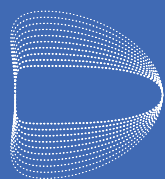

THP



Tire

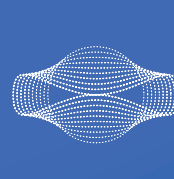

Heavy Duty
Composites

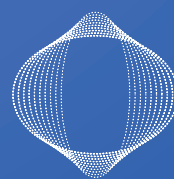

YCP

Tung Yu - Tailor-Made Solutions Provider

TungYu, certified to ISO 9001 and ISO 14064 standards and CE compliant, has been a trusted expert in hydraulic machinery since 1983. Tung Yu manufactures a wide assortment of products, from 5 tons hydraulic press to 15,600 tons conveyor belt production line and we offer a comprehensive One-Stop Shopping service for customers. Our product line includes: Compression Molding Machines, Rubber and Silicone (Solid/Liquid) Injection Molding Machine, Conveyor Belt Vulcanizing Machines, Tire Molding Machines, Retreading and Solid Tire Molding Machines.

東毓油壓機械股份有限公司，自1983創立以來，秉持著董事長楊楨彬先生之「穩健踏實、永續經營」經營理念，以「誠信」立足市場。『Tung Yu』品牌行銷全球七十餘國。承製能力範圍廣闊，鎖模力由5噸小型油壓沖床至15,600噸的輸送帶硫化機，均能承製。主要機械產品線：熱壓成型機、橡矽膠(固/液態)射出成型機、輸送帶硫化機、輪胎硫化機、翻新胎硫化機以及各式油壓機械，產品應用領域跨足各大產業。未來發展以創新為目標，深耕「力量與熱量載具」之核心技術，成為成型技術的領先者，為客戶創造最大價值。



總公司 Headquarters



南投市南崗工業區 Nantou City



中國寧波 Ningbo China

日本東京 日東株式會社
Japan - Tokyo Branch NITTO Co., Ltd.
印度孟買 孟買辦事處
India - India Branch, Tung Yu
(India) Liaison Office

TYC Series Machine Range

TYC 系列機型

05	Standard Range 基本標準機型	25	Demolding Mechanism 脫模機構說明
07	CE Certified Range CE 歐規標準機型	27	Optional Accessories 選購配備
11	Custom-made Machine 客製化機型	29	Technical Specification 機器規格表
15	Special Purpose Machine 特殊專用機型	30	Global Sales Network 全球銷售網路
24	Punch Machine 油壓沖床		

TYC Applications

TYC 系列機型成品類別

Automotive spare parts Industry:

Industrial oil seals, Automotive oil seals, Valve seals, Rubber seals, Packings, Tire valves, Rubber shock absorber

Information Industry: Electronics, Capacitor rubber seals, LED light sleeves, Rollers

Consumption Goods Industry: Consumer electronics, Seals, Mobile phone protection, Keyboard

Sports Industry: Tennis balls, Yoga mats, Golf balls, Golf clubs, Golf club handles, Air valves

Bicycle Industry: Rubber grips, Brake shoes, Rubber dust proof seals, Oil seals, O-rings

Carbon Composite Material:

Saddles, Carbon frames, Handle bars, Beverage cages, Carbon wheel sets, Cranks

Electronics Industry: Dielectric resonators and powder metal parts

Traditional Machining Industry: PTFE pipes, Grinding discs, Brake shoes

Lifestyle: Baby nipples, Cup caps, Cake molds, Ice boxes, Insulation mats, Silicon energy hand rings

Household Composite Material: Rubber tiles, Toilet seats

汽機車零件產業：工業用油封、汽機車用油封、汽門油封、橡膠密封件、迫緊、氣門嘴、減震橡膠

資訊產業：電子、電容器密封橡膠、LED燈管套、滾輪

消費性用品產業：3C產品、密封圈、手機保護套、鍵盤

運動用品產業：網球、瑜珈墊、高爾夫球、高爾夫球杆、高爾夫球杆握把、球類氣門嘴

腳踏車產業：把手、煞車塊、橡膠防塵套、防塵封、油封、O型圈

碳纖維複合材料：座墊、車架、車手把、飲料架、輪組、曲柄

電子產業：介電共振器、粉末冶金零件

傳統加工產業：鐵氟龍、砂輪片、煞車片

生活用品：奶嘴、水杯蓋、蛋糕模、冰塊盒、隔熱墊、矽膠能量手環

家庭用品複合材料：橡塑膠地磚、衛浴馬桶座



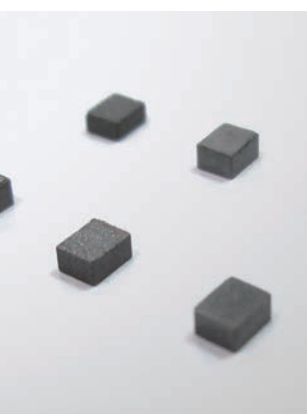
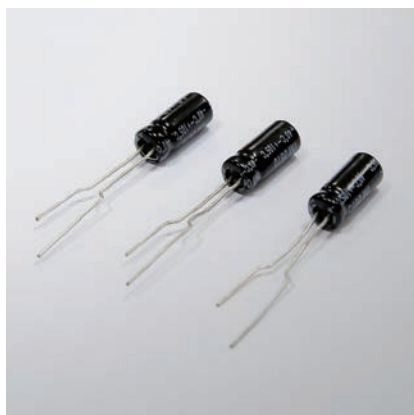
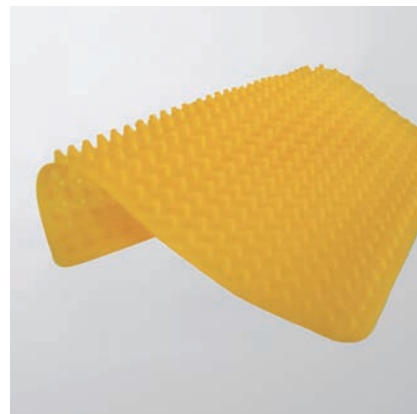
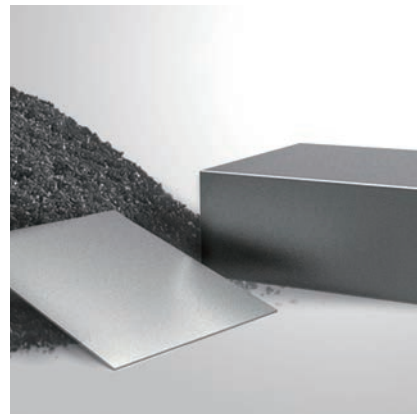

TYC-V

Vacuum Compression Molding Machine

真空熱壓成型機



TYC-V-2RT

Vacuum Compression Molding Machine

真空熱壓成型機



TYC-V-3RT

Vacuum Compression Molding Machine

真空熱壓成型機



CE Safety Conformity Type - Double Stations 歐洲CE安全規範機型－雙機型

Mechanical feature at a glance

- CE certificate for Machinery Directive 2006/42/EC.
- Safety Guarding with interlock plugs for operator protection.
- Safety Light Curtain TYPE 4 to comply with CE regulations .
- Custom design available for CE conformity presses.
- 機構設計完全符合歐洲CE安全規範。
- CE型安全圍網附有安全互鎖功能，確保操作人員之工作安全。
- CE型安全光幕(電眼)採用符合安規之TYPE 4 等級。
- CE型機構可依客戶要求承製。



Single Station 單機型



Each model certified
by CE Institute.

各機型皆經由 CE 認證單位
實際驗證取得證書。

Four Stations 四聯台機型



TYC-30-E-PCD-UP (CE)

All Electric Servo Press

全電伺服壓床

Mechanical feature at a glance

- "High torque at low speeds & hollow shaft" servo motor directly connects the ball screw to offer a gearless drive technology.
- High accuracy in both force and position, achieving high energy efficiency with low maintenance costs.
- 低轉速/高扭矩中空伺服馬達直驅滾珠螺桿，提供無齒輪驅動技術。
- 精準施力及加壓位置，實現高重複精度加工品質，維護成本低

Advantages 優點

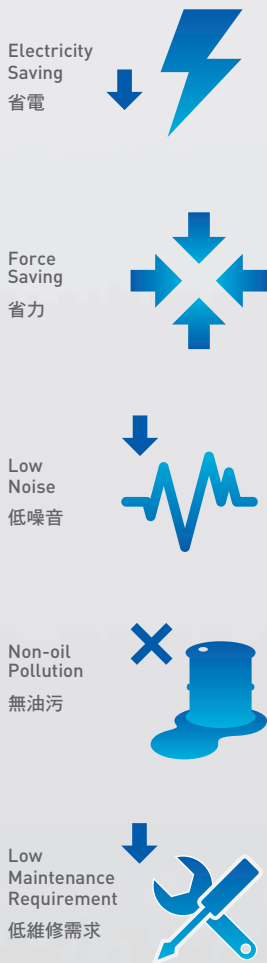

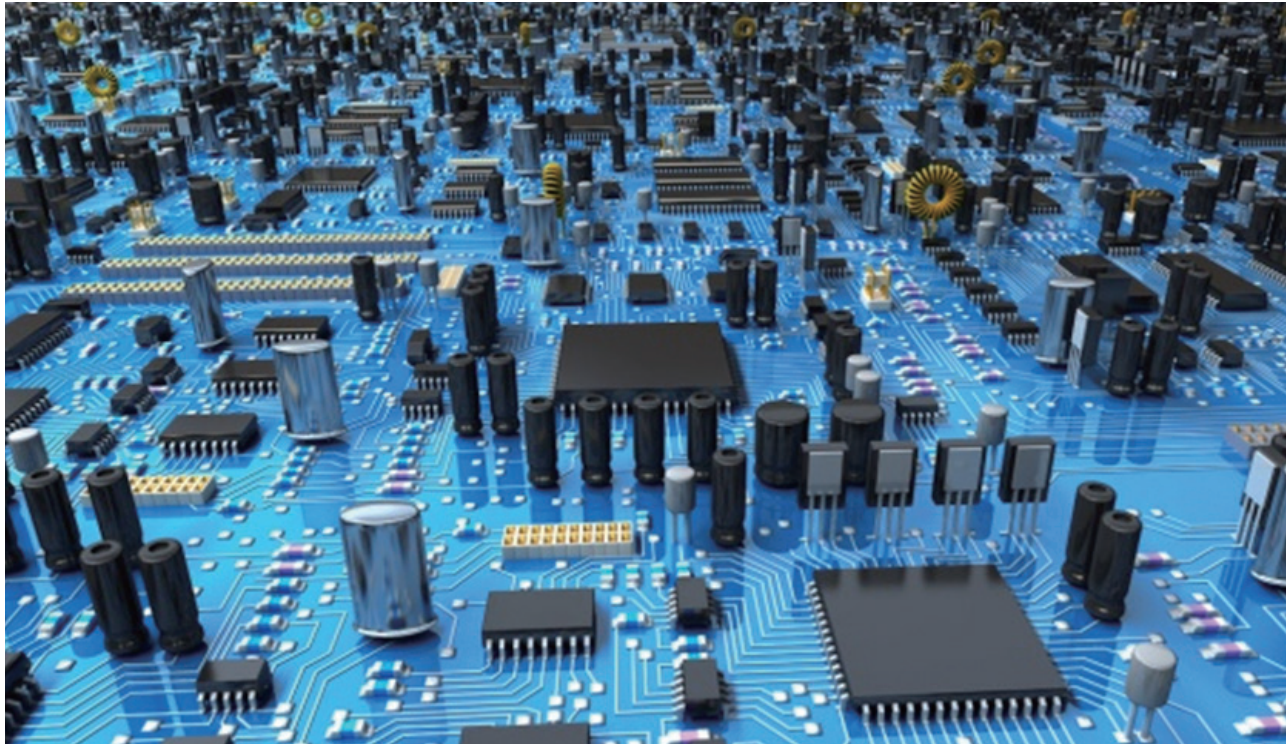

Products 製造成品

- Electronic parts
- High precision seals
- Pharmaceutical applications
- Composites
- 電子零件
- 高精度密封件
- 醫療用密封件
- 各類複合材料

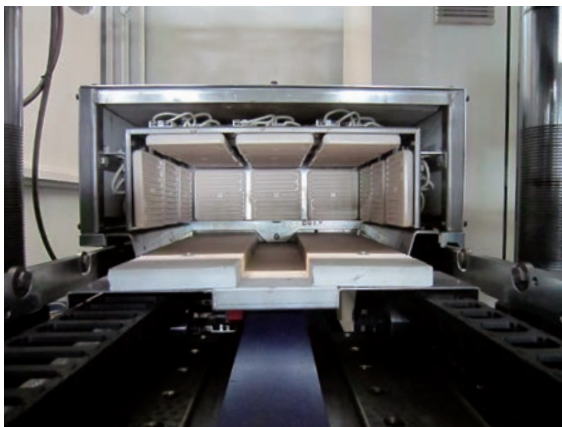

Compatible with ceramic heating and automated material feeding/unloading systems.
可搭配陶瓷加熱及自動送料/取料機構系統

TYC-V-18-R-2-S-PCD

Rail Type

軌道式機型

Mechanical feature at a glance

- Mold plate turnover at 60°, custom design available.
- 模板可60°翻板，方便成品取出，可提供客製化設計。

Products 製造成品

- O-rings / Gaskets / Rubber sheets / Keyboards
- O型環 / 墊片 / 橡膠薄膜 / 鍵盤





Tennis Ball Production Line 網球生產線專用機流程

• Optional punching machine 選配TPS-35沖床

R (RAIL): Rail Type 軌道式

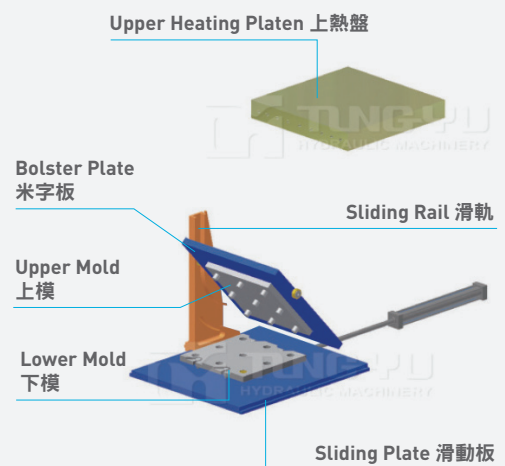

TYC-30-2RT-PCD-2L

Double Decks Shuttle Type

雙層出模機型

Mechanical feature at a glance

- Optional to use either single mold or two molds in production and shuttle for both sides, improve production efficiency greatly.
- 一次可同時加硫一副或兩副模具，並由前後同時取出成品，大幅提升生產效率。

Products 製造成品

- O-rings / Packings / Bike brakes / Miscellaneous rubber molded parts
- O型環 / 迫緊 / 腳踏車煞車片 / 各類橡膠雜件



TYC-10-PCD-3L-UP

Multi-Deck Type (Down Stroke)

多層開檔熱壓成型機（上置式）



Mechanical feature at a glance

- This model is designed for vulcanizing multiple molds in one simultaneous process, saving a great deal of time and production cost. (Safety fence is optional.)
- 一次可同時加硫多副模具，大幅節省時間成本。（此為附加安全圍欄機型）

Products 製造成品

- Clutches
- Brake linings
- Composites
- 汽機車離合器
- 煞車來令片
- 各類複合材料

TYC-V-26-3RT-S-PCD

Dual-Side Temperature-Controlled Type

雙邊換模恆溫控制機型



Mechanical feature at a glance

- Designed for dual-sided mold movement, this configuration allows efficient two-way production. Its energy-saving mold temperature control system ensures optimal performance with reduced power usage.
- 模具可左右滑移進行雙邊生產，搭配模具恆溫控制裝置，有效節省能源損耗並提升生產效率。

Products 製造成品

- Automotive Rubber Parts
- 車用橡膠件

TYC-22-3RT-S-PCD-UP

Ergonomic Type(Down-Stroke)

人體工學機型(上置式)

Mechanical feature at a glance

- Designed with a down-stroke mechanism and ergonomic features for enhanced operator safety and ease of use.
- 採用上置式油缸機構設計，結合人體工學理念，提升操作便利性與安全性。



TYC-V-12X6-A-S-PCD

Ergonomic Vacuum Forming Type

人體工學真空成型機型

Mechanical feature at a glance

- Equipped with a patented standalone mold-transfer device, ergonomically designed to align with the ideal operator height for efficient part release and mold demolding.
- 採人體工學高度設計的專利獨立送模機構，提供更舒適的操作體驗，提升產品脫模效率與安全性。



Products 製造成品

- Impact Protection Material
- Anti-Vibration Pad
- Automotive Cushion Pad
- O-Ring
- 防撞保護材
- 抗震墊
- 車用緩衝坐墊
- O型環

TYC-V-22-4RT-2-S-PCD-SP

Lateral Rubber Loading

連續轉射機型－側進式

Mechanical feature at a glance

- Advanced 3 and 4-layer continuous transfer injection with vacuum design.
- Injection pot equipped with cooling system for consistent molding.
- Double stations configuration, with lateral or rear loading that save space and increase productivity.
- 創新真空三層及四層出模連續轉射技術。
- 加硫過程中原料置於原料槽搭配冷卻系統可多次使用，改善傳統每模投料的殘料浪費，大幅節省成本。
- 雙機構型，原料槽可設計於兩側或後側進出，節省空間，增加產能。

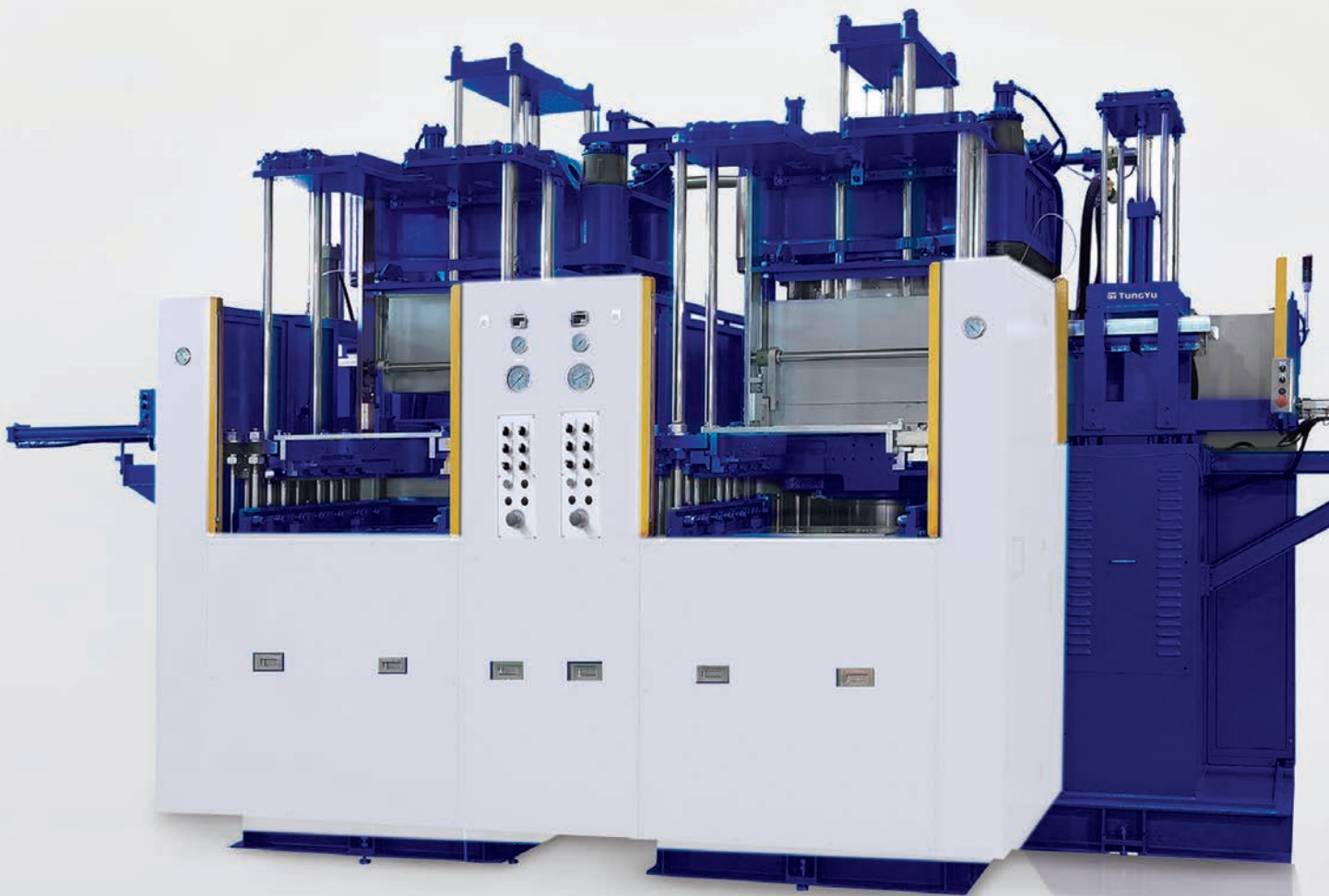

TYC-16-S-PCD-SP

Rear Rubber Loading 連續轉射機型－後進式



Products 製造成品

- Valve stem seals
- Air valves
- Anti-vibration rubber for electronics
- Capacitor rubber seals
- 汽門油封
- 球類氣門嘴
- 電子用避震矽膠
- 電容器密封橡膠

TYC-24-A-S-PCD-SP

Top Transfer Injection Type -
Ergonomics Low Working Height
上置式轉射機型 - 低床型設計

Mechanical feature at a glance

- Ergonomics design : moving spacer for low working height.
- Multi-stage settings for pressure and time.
- Concealed position control system.
- Fully safety caging protection complies with CE standard.
- 低床型專用之移動墊塊。
- 多段式加壓和時間設定。
- 隱藏式定位系統。
- 完善的CE安全保障措施。





Products 製造成品

- Aeronautic cabin applications
- Rubber rollers
- Big size piping seal connectors
- 航空機艙
- 橡膠類滾筒
- 大型水管接頭

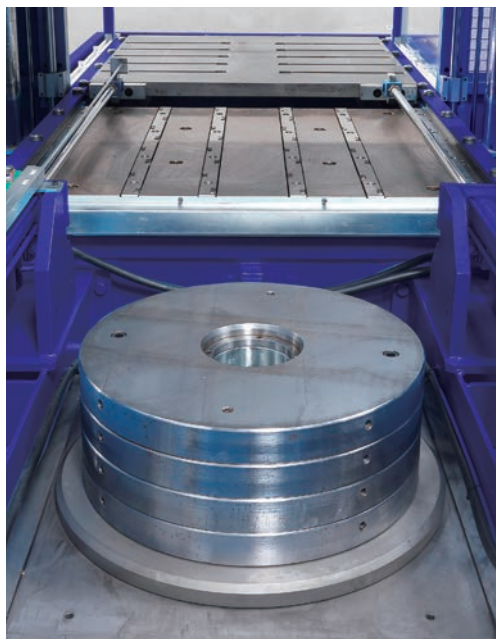

Features 特寫說明

- Add or remove spacers for mold height.
- Equipped with temperature regulator for flexible temperature setting.
- 可根據不同的模具高度調整墊塊數量，以達到所需之行程。
- 採用溫度調節控制系統，客戶可依據各樣膠料調整所需溫度。

TYC-V-32-S-PCD-2L-UP

Clean Room Double Layer Vacuum Compression Molding Machine(Down Stroke)

無塵室級雙層真空熱壓成型機(上置式)

Mechanical feature at a glance

- Specially designed for clean room to make all types of precision rubber products.
- Simultaneous vulcanization of dual molds raises production efficiency.
- 無塵室專用設計，可生產各種精密橡膠製品。
- 可同時加硫兩副模具，大幅提升生產效率。

Products 製造成品

- Medical stoppers
- Pharmaceutical applications
- 醫療用瓶塞
- 醫療用密封件





Clean Room Vacuum Compression Molding Machine

無塵室級真空熱壓成型機



Clamping Unit fully sealed to prevent from foreign particle.
合模機構採無塵密封設計，阻絕外部汙染

TYC-14-3-S-PCD-2L(CE)

Multi-station Hot/Cold Forming Machine

多聯台冷熱壓成型機

Mechanical feature at a glance

- Multi-station design allows multiple workstations to be configured according to different product requirements, making it suitable for multi-step forming processes.
- Features both hot and cold forming capabilities, making it ideal for complex and precision products while enhancing production efficiency and accuracy.
- 靈活多聯台設計，可根據不同產品需求配置多個工作站，適用於多步驟成型製程。
- 兼具冷、熱成型功能，適合複雜精密的產品，提高生產效率與精度。

Products 製造成品

- Aerospace parts
- High-strength seals, shock absorber bushings, heat-resistant gaskets
- 航太配件
- 高強度密封件、避震器襯套、耐熱墊圈



Punch Machine 油壓沖床

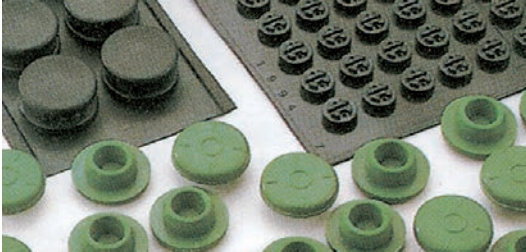

Mechanical feature at a glance

- This machine is designed especially for cutting the final products, capacitor and medical products.
- 適用於橡膠成品沖斷、電容器橡膠封口、瓶塞及醫療器材等橡膠另件。



ITEM 項目		TPS-35-PC
Cylinder (main frame)	主機油缸	FA 150 x 110
Cylinder (ejector)	拍板油缸	FA 50 x 125
Cylinder (shuttle mold)	送模油缸	FA 40 x 265
Punch force	總出力	35 tons
Working pressure	油壓使用壓力	200kg / cm ²
Horsepower	使用馬力	7.5 HP
Blow material system	吹料裝置	Compressed air 壓縮空氣
Safety system	安全裝置	Start by hand 雙手啟動
Net weight	機械重量	1230kg
Gross weight	裝箱重量	1430kg
Wooden package size	裝箱尺寸	L1540 x W1130 x H1800

Mechanical feature at a glance

- Suitable for hardware punching, such as bearing, bushes and wire guide assembly.
- 適用於五金零件沖壓，配合軸承、軸襯及裝配導線作業。

TYPE 型號	Output 出力	Stroke 行程	Piston dia. 活塞桿直徑	Horsepower 馬力	Falling speed 下降速度	Lifting speed 上升速度
TPS-5	5	200	55 m/m	3HP x4P	2.5 (m/min)	4.8 (m/min)
TPS-10	10	250	80 m/m	5HP x4P	3.7 (m/min)	10.3 (m/min)
TPS-15	15	250	90 m/m	5HP x4P	2.3 (m/min)	4.9 (m/min)
TPS-20	20	250	100 m/m	5HP x4P	3.7 (m/min)	2.9 (m/min)
TPS-30	30	300	100 m/m	71/2HP x4P	2.5 (m/min)	4.5 (m/min)
TPS-40	40	300	125 m/m	71/2HP x4P	3.9 (m/min)	3.4 (m/min)



Optional Features 選配項目

From feeding and clamping to demolding, Tung Yu tailored solutions based on your product and mold design. Our versatile systems adapt across industries—built to handle every challenge with precision.

彈性選配模組，滿足各式生產需求。從入料、合模到脫模流程，東毓依產品特性與模具設計，打造最適化的專屬解決方案，廣泛應用於多元產業，靈活應對每一種挑戰。

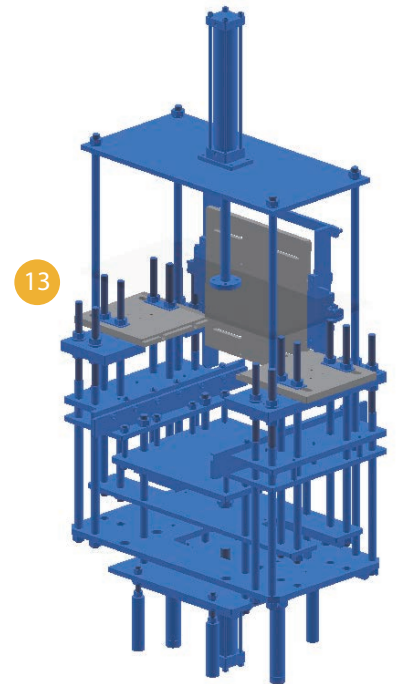
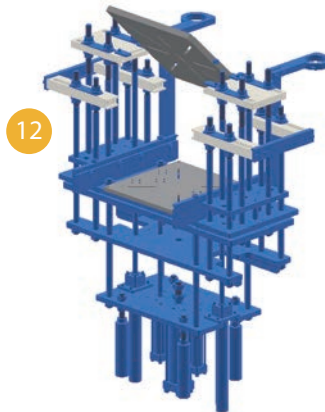
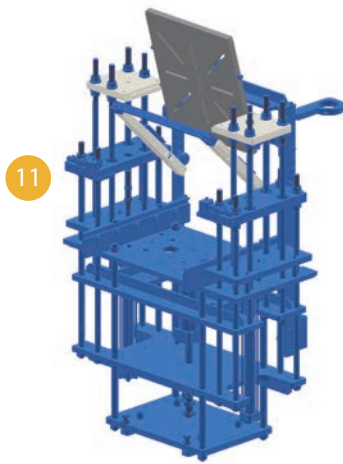
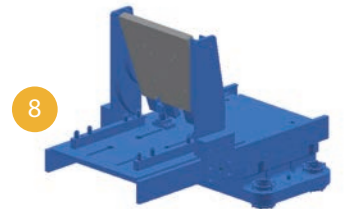
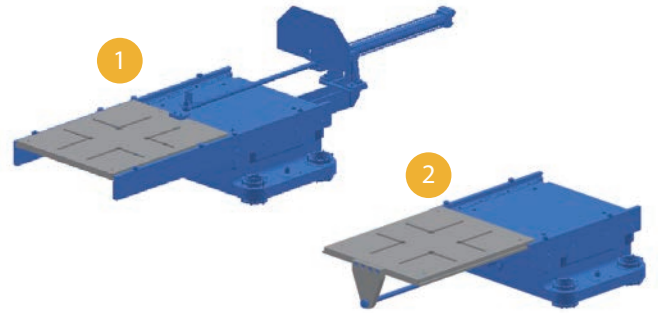

1	Shuttle Cylinder At Rear	送模油缸(後置式)
2	Shuttle Cylinder At Middle Traverse	送模油缸(中座式)
3	Safety Fence	圍網
4	Vacuum Chamber	真空罩
5	Bottom Ejector	下吊模

6	Air Jig Cylinder
7	Top Ejector
8	Rail-Type Demolding Way
9	2-Layer Mold (2RT) Demolding Way
10	3-Layer Mold (3RT) Demolding Way

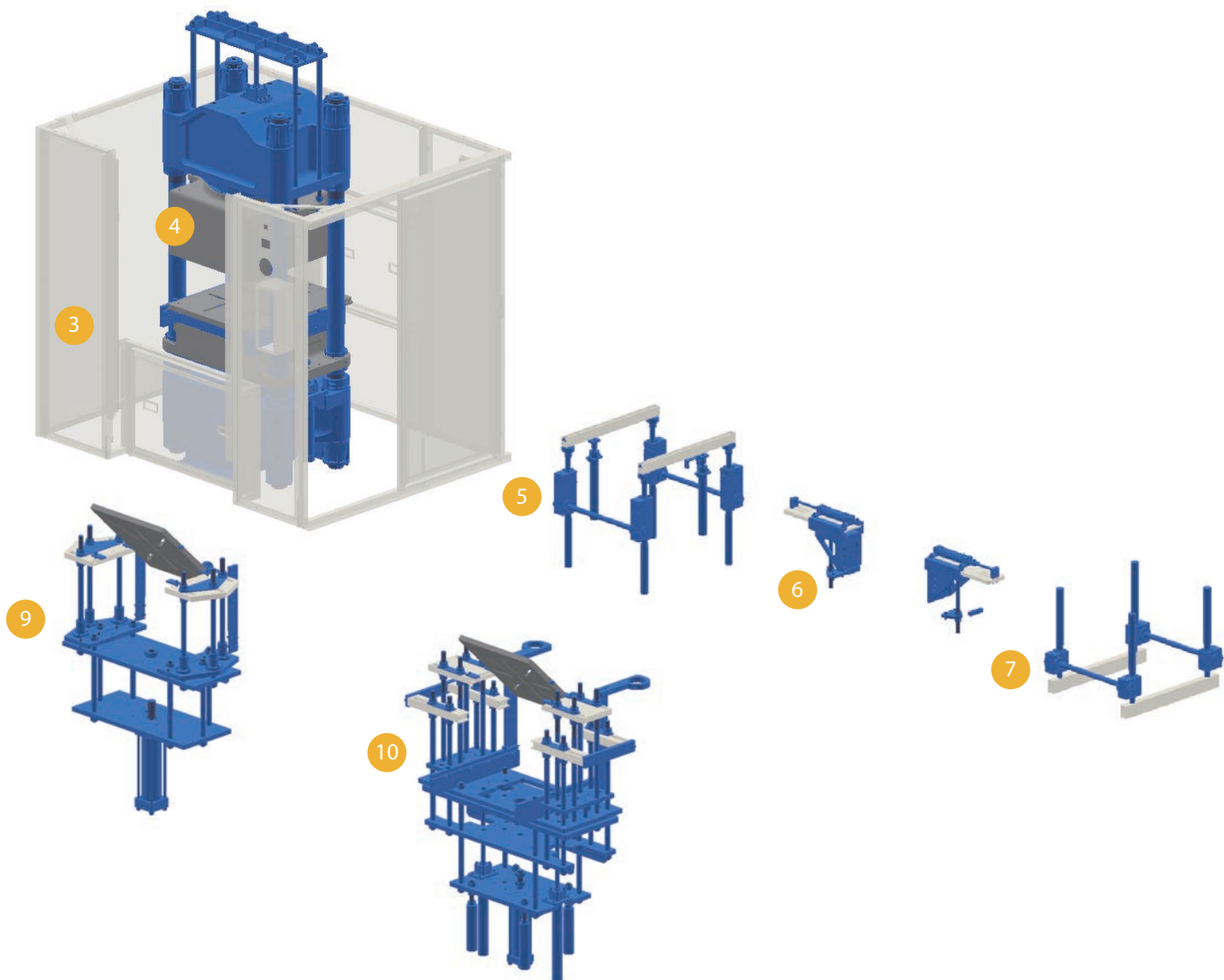

Remarks 備註
 • Other customized design is available.
 • 規格可依需求客製化設計。

離型插銷	11	3RT with Dual Tilting Plate Mechanism	三層模具離型+雙翻板
上吊模	12	3RT Plate Mechanism & Lower Knock-Out Device	三層模具離型+下拍
軌道式模具離型			
雙層模具離型	13	3RT with 90° Tilt & Upper Knock-Out Device	三層模具離型+上翻90°+上拍
三層模具離型			

Optional Accessories 選購配備



Energy Management Monitoring System 能源管理監控系統

Electricity monitoring devices fulfill energy management needs. The energy dashboard provides trend charts for voltage, current, cumulative electricity usage, and carbon emissions, enabling real-time monitoring of carbon output.

透過電量監控器，達到能源監控需求。能源畫面可顯示電壓、電流、累計電量與碳排放的趨勢圖，即時掌握碳排數據。



Linear Transducer 位置尺

Available to monitor stroke values and settings on touch screen.

透過人機可監控並設定油缸的行程。



Safety Sensor & Light Curtain 安全電眼

Combined with PLC control system, ensures full protection of operators.

搭配PLC控制程式，確保操作人員安全。

Hydraulic Servo System 油壓伺服節能系統

Accurate force and pressure control to achieve high repeatability in machining quality, resulting in energy savings of 50%~80%.

精準控制施力及加壓位置，實現高重複精度加工品質，節能效益高達50%~80%。



Electricity Saving
高省電



Low Noise
低噪音



High Efficiency
高效率



High Accurate
高精密



Output Ampere 輸出電流

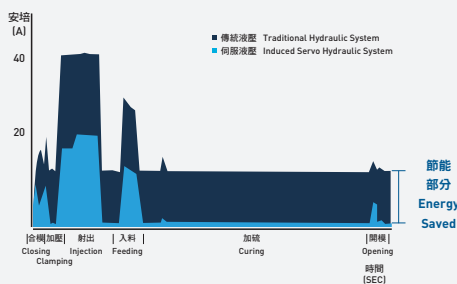

Power Consumption Per Cycle 單次功率累計

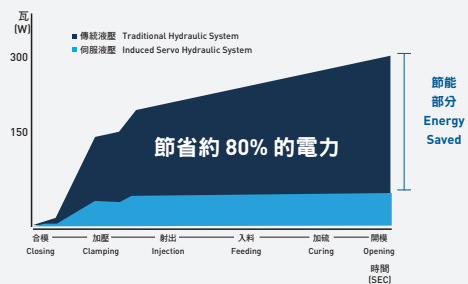



Top / Bottom Hydraulic Lateral Ejectors 上下吊模

To synchronize several opening levels. Guiding rods connected through a rack and pinion system.

上 / 下吊模裝置可運用於不同高度，雙側導桿與齒排相連並有機械式同步裝置。

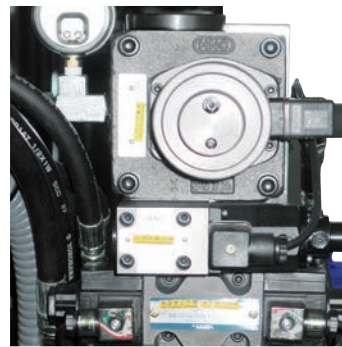

Proportional Pressure and Flow System 比例式壓力流量系統

Value setting on touch screen, increased precision of flow and pressure control.

數據於觸控螢幕上設定，壓力及流量控制更精確。



USB Mould Saving USB 模具儲存裝置

USB for mould saving on front cabinet.

電控箱前方設置USB供模具儲存使用。

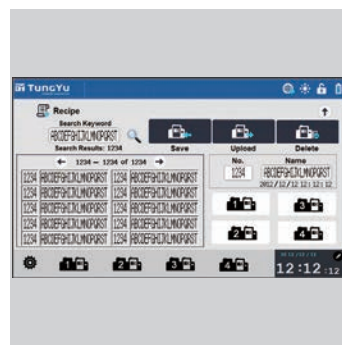

Mold Memory Keywords 模具記憶關鍵字

Quickly stores and retrieves key mold data for efficient management.

快速儲存與查詢模具數據，提升管理效率。

Safety Guard & Cage 安全護罩

Ensures fully protection of operator and reduces heat loss. 確保操作人員安全，同時減少熱源散失。



Full cage 全包式



Pneumatic safety door 氣壓式安全門



Front kit with acrylic cover 壓克力罩

TYC Model Guide 型式說明

TYC		—		—		—		—		—		S		—	
Column (post) Type 柱型		Vacuum Device 真空裝置		Piston Dia. (inch) 活塞直徑(英寸)		Layer of Mold Strip 離型模數		No. of Station 連結台數		Main Ram Outside Type 主缸外露型		Control System 電氣控制方式			
Code 代號	Description 說明	Code 代號	Description 說明	Code 代號	Description 說明	Code 代號	Description 說明	Code 代號	Description 說明	Code 代號	Description 說明	Code 代號	Description 說明		
Omit 無	No Vacuum 無真空	10	(=100 tons)	Omit 無	Open & close 無出模	Omit 無	Single station 單機					PCD	PLC+HMI (touch screen) PLC+觸控螢幕		
V	Vacuum 有真空裝置	12	(=150 tons)	A	Lower plate shuttle out 下模板出模	2	Double stations 雙聯台								
		14	(=200 tons)	R (Rail)	Rail (clam shell) type 軌道出模	3	Three-station 三聯台								
		16	(=250 tons)	2RT	2-layer mold strip 二層脫模	4	Four-station 四聯台								
		18	(=350 tons)	3RT	3-layer mold strip 三層脫模										
		22	(=500 tons)	4RT	4-layer mold strip 四層脫模										

Technical Specifications 機器規格表

Machine Type	機型		TYC-V-10-	TYC-V-12-	TYC-V-14-	TYC-V-16-	TYC-V-18-	TYC-V-22-	
Clamping Force	鎖模力	ton	100	150	200	250	350	500	
Heating Platen Size (L.R. x F.B.)	熱盤尺寸(左右x前後)	mm	405x430	450x480	505x510	570x610	700x700	700x700 / 800x800	
Daylight (max.)	最大開檔	mm	300						
Stroke (max.)	最大行程	mm	250						
Heater Capacity Per Station	電熱容量(熱盤)	kW	8.76	10.56	17.4	19.2	22.6	22.6 / 39.2	
Connection Station Per Set	可連結台數		1,2,3,4				1,2		
Turnover Degree	翻模角度	°	45°						
Piston Diameter	活塞直徑	mm	250	300	355	400	457.2	560	
Vacuum Stroke	真空罩缸行程	mm	160	160	160	200	200	200	

Remarks 備註

- Custom design available.
- 規格可依需求客製化設計。

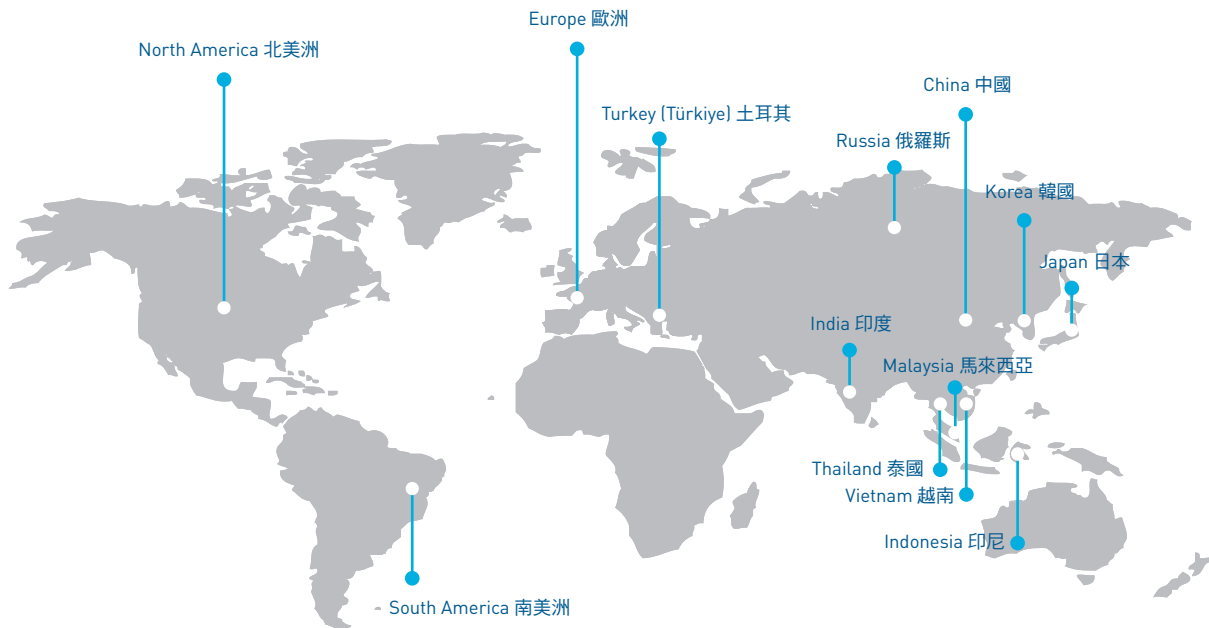

Japan - Tokyo Branch 日本分公司

株式會社 日東
NITTO Co., Ltd.
東京都台東区東上野1-20-6丸幸ビル602
602 Maruko Building, 1-20-6 Higashiueno,
Taito-Ku, Tokyo 110-0015 Japan
T + 81 3 5812 2812 F + 81 3 5812 2815
info@kk-nitto.co.jp
www.kk-nitto.co.jp/index.html

Turkey (Türkiye) 土耳其 代理商

Vizyotek San.Mak.Paz.Bak. Ve Ser.Hiz. San.
Tic.Ltd. Sti.
21.yy Cd. 18.Sk. Zigana Sit. No.4 Bademli
Bursa Türkiye
T + 90 224 5491208 F + 90 224 5491209
vizyotek@vizyotek.com.tr

Germany 德國 代理商

REP Deutschland GmbH
Sauergasse 5-7 D-69483
Wald-Michelbach - Deutschland
T + 49 6207 9408 0 F + 49 6207 9408 29

Tung Yu (India) Liaison Office 印度孟買 辦事處

Salnik Solutions&Tung Yu (India) Liaison Office
509-510 A'Wing, 4th Floor, Orchard Mall Rd.,
Royal Palms Estate, 169-Aarey Milk Colony Rd.,
Goregaon (East), Mumbai - 400 065, India
T + 91 22 2877 6547 F + 91 22 2877 3147
tungyu@tungyuindia.com

Korea 韓國 代理商

Jugi Corporation
Room No. 916, 129, Bongeunsa-ro
(Nonhyun-dong Geopyeong Town),
Gangnam-gu, Seoul, 06121 Korea
T + 82 2 5478254 F + 82 2 5488254
info@jugicorp.com

United Kingdom 英國 代理商

Rep Rubber Injection Ltd
T + 44 0759 688 3260
Gary.anderton@repuk.co.uk

Europe 歐洲 代理商

Rep International
15, rue du Dauphine 69960 Corbas, France
T + 33 4 72215353 F + 33 4 72512235
commercial@repinjection.com

Thailand 泰國 代理商

Centre West International (Thailand) Co., Ltd.
100 Moo 13, Soi Santi Na Khon 14, Bang Keaw,
Bang Phli, Samut Prakan 10540 Thailand
T + 66 2753 7201 F + 66 2753 6925
Mobile + 60 1221 88972
derek@centrewest.com.my

Russia 俄羅斯 代理商

Rti-Snab Ltd.
Polzunova st. 3, Tula 300028, Russia
T/F + 7 4872 656367
M + 7 985 7617422
rti-snab@yandex.ru

North America 北美洲 代理商

Rep Corporation
310 Katom Dr, Kodak, TN 37764, United States
T + 1 847 697 7210 F + 1 847 697 6829
dwilliams@repcorp.com

Malaysia 馬來西亞 代理商

Centre West Industrial Supplies Sdn. Bhd.
No. 9, Jalan TSB 8, Taman Industri Sungai
Buloh, 47000 Petaling Jaya Selangor,
Malaysia
T + 60 3 6157 6688 F + 60 3 6157 0651
Mobile + 60 1221 88972
derek@centrewest.com.my

South Vietnam 南越南 代理商

CÔNG TY TNHH CHIEH KE INT'L VN
杰格國際越南責任有限公司
Ap An My, Xa An Dien, Huyen Ben Cat, Tinh Binh
Duong, Vietnam
T + 84 650 3554128/29/30/31 F + 84 650 3554166
chiehkevn@gmail.com
sales@full-shine.com

Indonesia 印尼 代理商

PT. Asia Talenta Mandiri
CBD@Jababeka Blok F-21, Jl. Niaga Raya Kav.
AA3, Jababeka, Cikarang, Bekasi, Jawa Barat 17530,
Indonesia.
T + 62(0)21 2908 2716 F + 62(0)21 2908 2803
yogisuson@gmail.com

Brasil 巴西 代理商

REP INJETORAS DE BORRACHA LTDA
Rua Amorim Diniz, 60 Sala 01 - Jardim
Jaú03730-040 São Paulo - SP
T + 55 11 9 9965 8661
mcarvalho@repinjection.com

Affiliates 關係企業

G-WAY 吉瑞精機

G-WAY Machinery Industrial Co., Ltd
540 南投市永興路12號(南崗工業區)
No. 12, Yongsing Rd., Nan Kung Industrial Zone,
Nantou City 540, Taiwan R.O.C.
T + 886 49 2258239 F + 886 49 2258229
gway@tungyu.com
www.g-way.com.tw



台灣總公司 Headquarters

東毓油壓機械股份有限公司
Tung Yu Hydraulic Machinery Co., Ltd.

540 南投市永興路12號 (南崗工業區)
No. 12, Yongxing Rd., Nangang Industrial Park,
Nantou City, Nantou County 540, Taiwan

T + 886 49 2253588 **F** + 886 49 2252998 **E** tungyu@tungyu.com

中國寧波公司 China Ningbo

東毓(寧波)油壓工業有限公司
Tung Yu (Ningbo) Hydraulic Industries Co., Ltd.

315221 中國浙江省寧波市鎮海區蛟川街道東信路666號
No. 666, Dongxin Road, Jiaochuan Street, Zhenhai District,
Ningbo City, Zhejiang Province, China.

T + 0574-55333028 **F** + 0574-86598057 **E** ningbo@tungyu.com

全國免費服務專線 Free Hot Line 40011-33028